



Bodybuilder's Bulletin (New Truck Generation)

14 April 2022

Bulletin No. 139.1

Connections to the Bodybuilder Interface Module (KSM)

With the launch of the MAN New Truck Generation (New TG), the connections for bodybuilders have changed. This bulletin lists all of the new connections that bodybuilders should use for interaction with the New TG range.

MAN recommend that an Interface Module is specified on the vehicle from new to allow bodybuilder's equipment to communicate with the vehicle's CAN-bus systems.

MAN UK recommends code 0P2NA "*Interface for data exchange with body (customer-specific control module) and intermediate engine speed (ZDR), behind front panel and behind cab*" is specified with every vehicle order.

In addition, code 0PHPE "*Interface for data exchange with body (customer-specific control module) and intermediate engine speed (ZDR), behind front panel and behind cab*" can be specified, which gives the same functionality as 0P2NA but with the addition of an extra set of connections at the rear of the cabin.

Option code 0P2NA includes 3, sockets: X6491, X6492 and X6493. If the vehicle was built before May 2021 (Picture 1) these are located under the front flap and function parameter 81.25891-0173 will be installed in the vehicle. If the vehicle was built after May 2021, the vehicle has X7435 instead of X6492, the pins allocation is the same as X6492 but the location is as per Picture 2

Should you have any queries on the above, please contact Sales Engineering on 01793 448000 or Email Salesengineering@man.eu

Please circulate and then retain in the Body Builders Manual.

Picture 1

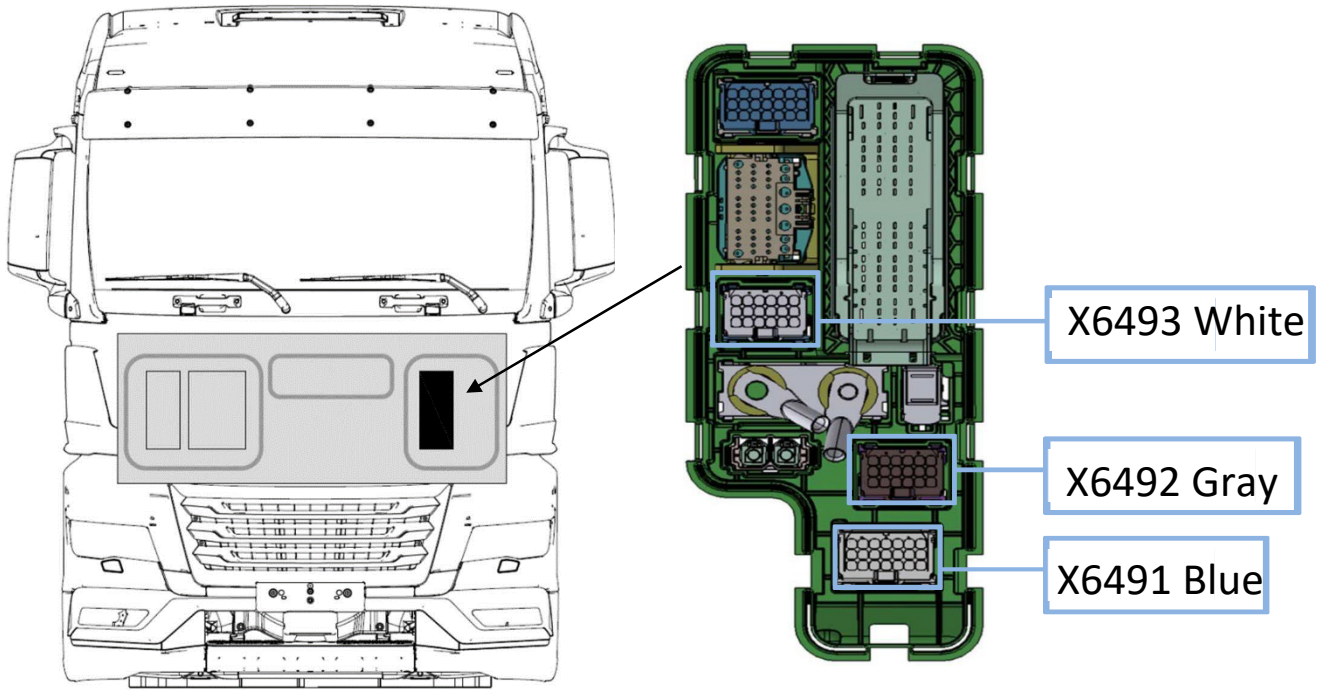

Picture 2

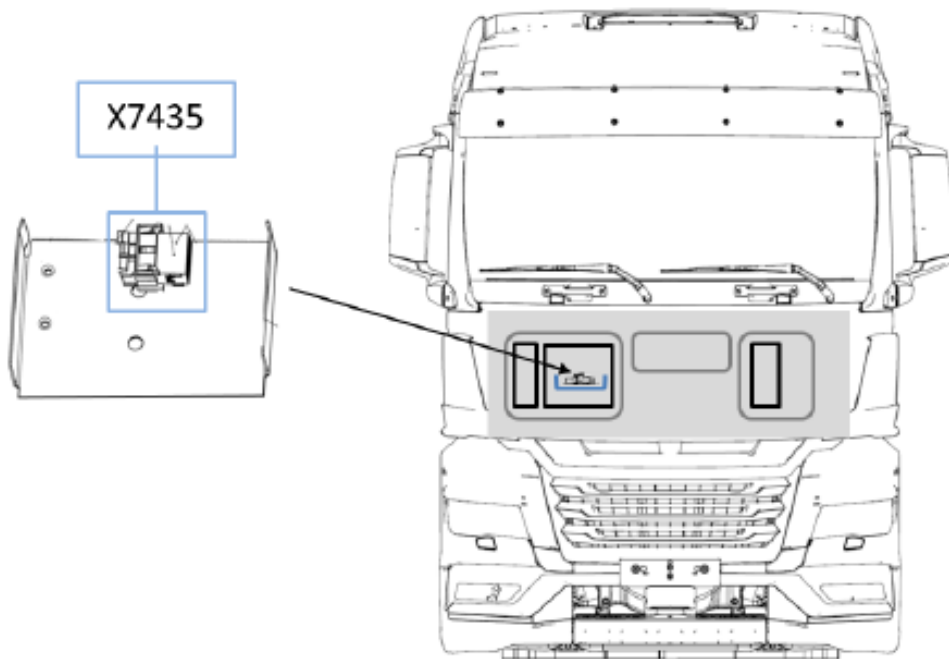

Should you have any queries on the above, please contact Sales Engineering on 01793 448000 or Email Salesengineering@man.eu

Please circulate and then retain in the Body Builders Manual.

Connector X6491

Connector X6491 provides engine speed limits, engine speed request for increase or decrease engine speed, output signals and connections for the "A" CAN.

Activating the DrzMomBgr pins (6491/Pin 1 and 2) permits selection of the engine speed and torque limit parameters.

Factory settings:

Signal	Engine speed	Torque
Engine speed/torque limit 1	1500U/min	100%
Engine speed/torque limit 2	1800U/min	100%
Engine speed/torque limit 3	1200U/min	100%

A breakdown of what pin function X6491 has as the default setting is below in table 1:

Table 1

Connecting plug	Cable number	Function
X6491/1	751043	DrzMomBgr 1+3
X6491/2	751044	DrzMomBgr 2+3
X6491/3	751045	LS1_ Config (factory setting: Accelerator pedal
X6491/4	751046	LS2_ Config (factory setting: low oil pressure warning)
X6491/5	751047	HS1_ Config (factory setting: hand brake)
X6491/6	751048	HS2_ Config (factory setting: Brake)
X6491/7	751049	HS3_ Config factory setting: R_Gear)
X6491/8	751050	HS4_ Config (factory setting: Clutch)
X6491/9	751051	LS3_ Config (factory setting: Gearbox-N)
X6491/10	751052	Telltale lamp (disruption KSM)
X6491/11	751053	HS5_ Config (factory setting: Engine speed limit 2
X6491/12	751054	Operating readiness (KSM)
X6491/13	751055	SET+ (Increase engine speed)
X6491/14	751056	SET- (Decrease engine speed)
X6491/15	751057	OFF; external bridge between Pins 12 and 15
X6491/16	751058	MEM
X6491/17	032027	A-CAN –H
X6491/18	032028	A-CAN –L
X6491/19	751042	Engine speed 2

Should you have any queries on the above, please contact Sales Engineering on 01793 448000 or Email Salesengineering@man.eu

Please circulate and then retain in the Body Builders Manual.

The standard output low side (earth) or high side (positive) for plug X6491 can be found in table 2, indicated by an X.

Any of the signals can be exchanged for another option by reprogramming with the MAN diagnostic equipment, (cost will apply for this service), for more information about the function below, please visit the: [Interface ZDR with data exchange Edition 2020 V2.0](#)

Table 2

	Ls_konfig / Hs_konfig	low-side switch			high-side switch				
		Ls1	Ls2	Ls3	Hs1	Hs2	Hs3	Hs4	Hs5
	Interface X6491	Pin3	Pin 4	Pin 9	Pin 5	Pin 6	Pin 7	Pin 8	Pin 11
	max. Load	2500mA	2500mA	2500mA	2500mA	2500mA	2500mA	2500mA	2500mA
Nr.	Signals:								
0.	not in use								
1	Gearbox-N			X					
2	ABS-active								
3	handbrake				X				
4	Brake					X			
5	R-Gang								
6	Clutch							X	
7	Kick-down								
8	Idle								
9	Speed limit 1 on								
10	Speed limit 1 on/off								
11	Engine speed limit 1 on								
12	Engine speed limit 1 on/off								
13	Fuel level warning								
14	Speed limit 2 on								
15	Speed limit 2 on/off								
16	Engine speed limit 2 on								
17	Engine speed limit 2 on/off								X
18	PTO 1 feedback								
19	PTO 2 feedback								
20	NMV feedback [front-end PTO]								
21	Oil pressure warning		X						
22	Coolant overheat warning								
23	Split								
24	Accelerator pedal threshold on/off	X							
25	Brake pedal threshold on/off								
26	Axle load 1 warning								
27	Axle load 2 warning								
28	active blackout light mode								
29-32	Reserved								
33	Cabin tilt lock								
34	Preselected neutral gear								
35	Preselected reverse gear						X		
36	Parking light								
37	Low beam								
38	High beam								
39	Indicator left								
40	Indicator right								
41	Hazard lights								
42	Error detected								

x = Factory setting

Should you have any queries on the above, please contact Sales Engineering on 01793 448000 or Email Salesengineering@man.eu

Please circulate and then retain in the Body Builders Manual.

The MAN part numbers for the X6491 (blue) connector are below if you are intending to add wires into the existing empty plug then only choose a blade terminal base on the wire size. If you want to build a loom to plug into the vehicle, you will need the connector body and the secondary lock.

Contacts X6491	MAN Part No
Blade Terminal up to 1.5mm wire size	07.91201-0644
Blade Terminal for 1.5 to 5mm wire size	07.91201-0643
Matting connector (body)	81.25432-0548
Secondary lock for housing	81.25435-0974

Through "A" CAN pins 17 & 18 in X6491 it is also possible to read and control some functions of the vehicle; table 3 below provides a list in Column 1

Table 3

Message	Column 1 Bodybuilder interface for external engine intermediate speed and data exchange 81.25891-0173 (Code: 0P2NA)	Column 2 Fleet management system with Driver-ID 81.25891-0684 (Code: 0P2J3)	Column 3 Fleet management system without Driver-ID 81.25891-0685 (Code: 0P2J3)
ETC1	X		
ETC2	X		
ETC3	X		
Ccveh_speed	X	X	X
EBC1	X		
AUX_STAT_ZBR1	X		
EEC1	X	X	X
EEC2	X	X	X
EngFlui_LevPre	X		
Eng_Temp	X	X	X
Air Supply pressure	X		
Amb_Cond	X	X	X
Time_Date	X		
Veh_dist	X	X	X
Eng_HourRev	X	X	X
Veh_Weight_EBS	X	X	X
Veh_Weight_ECAS	X	X	X
TCO1	X	X	X
ERC1_RX	X		
FMS-standard Interface		X	X
Service		X	X
Fuel_cons	X	X	X
VIN		X	X
Dash Display	X	X	X
ERC1_RE	X		
ERC1_RD	X		
Fuel_Eco	X	X	X
Aux_Stat_KSM1	X		
HRFC	X	X	X
DI		X	
Tank_info	X		
AUX_STAT_MC1	X		
EBS22	X		
ASC1	X		
ASC3	X		
cruiseCtrlVehicleSpdSetu	X		
operatorExtLghtCtrlMsg	X		
EEC3	X		

Should you have any queries on the above, please contact Sales Engineering on 01793 448000 or Email Salesengineering@man.eu

Please circulate and then retain in the Body Builders Manual.

engineConfiguration	X		
engineFluids	X		
lightningData	X		
cabIllumination	X		
vehicleElectricalPower	X		
EBC2	X		
doorControl2	X		
VDC2	X		

Connector X6492/X7435

Connector X6492/X7435 is the plug for ZDR interface:

For each power take-off (NA1, NA2, NMV) any ZDR mode (ZDR1, ..., ZDR7) can be ascribed. The ZDR request is created when a feedback signal of the chosen power take-off is present.

ZDR Setting	Connect NA (PTO) Feedback Signal Pin 1 to Pins:
ZDR1	2
ZDR2	7
ZDR3	2 and 7
ZDR4	8
ZDR5	2 and 8
ZDR6	7 and 8
ZDR7	2, 7 and 8

More information about ZDR settings can be found at:

https://www.manted.de/ZDR_Edition_2020_V2.0_en.pdf

The MAN part numbers for the X6492 (Gray) connector are below. If you are intending to add wires into the existing empty plug then only choose a Blade terminal base for the wire size. If you want to build a loom to plug into the vehicle, you will need the connector body and the secondary lock.

Contacts X6491/X7435	MAN Part No
Blade Terminal up to 1.5mm wire size	07.91201-0222
Blade Terminal for 1.5 to 5mm wire size	07.91201-0224
Matting connector (body)	36.25435-0017
Secondary lock for housing	81.25435-0973

Should you have any queries on the above, please contact Sales Engineering on 01793 448000 or Email Salesengineering@man.eu

Please circulate and then retain in the Body Builders Manual.

Connector X6493

Connector X6493 is the plug for the extended ZDR interface & will include the engine stop/start function is specified:

Below give the pin function X6493 plug

Connecting plug	Cable number	Function
X6493/1	150001	Term. 15 central electrics
X6493/2	233010	Control Cooling "Truck "(Button 1) ²
X6493/3	605008	Step contact ASF reverse restriction
X6493/4	605010	Clutch released / external Gearbox N request
	233011	Control: Thawing / De-icing "truck "(Button 2) ²
X6493/5	401016	NMV demand ¹
	231035	Response: Cooling "Truck "(Button 1) ²
X6493/6	401017	NMV- Telltale light ¹
	231036	Response: Thawing / De-icing "truck "(Button 2)
X6493/7	233012	Control: Cooling "Trailer" (Button 3) ³
X6493/8	703000	Switch Trailing axle "Trailer" ⁴
X6493/9	701000	Button Moving-off aid "Trailer" ⁴
X6493/10	310000	Term. 31 (earth) ⁴
X6493/11	701001	Telltale light: Moving-off aid "Trailer" ⁴
X6493/12	403001	SSNA-Activation magnetic valve ⁵
X6493/13	401018	SSNA- Response ⁵
X6493/14	503000	External engine start ⁶
X6493/15	433000	External engine stop ⁶
X6493/16	233013	Control: Thawing / De-icing "trailer" (Button 4) ³
X6493/17	605023	Response: Cooling "Trailer" (Button 3) ³
X6493/18	605008	Response: Thawing / De-icing "trailer" (Button 4) ³

1. 1 only with fitted NMV
2. 2 only with fitted preparation for cooling aggregate 1 piece (for Truck)
3. 3 only with fitted preparation for cooling aggregate 2 pieces (for Trailer)
4. 4 only with fitted preparation control possibility Lift-/ Dis-charging trailer axle
5. 5 only with preparation for a switchable pump on SSNA (circuit, electrical, for power take-off, engine
6. speed-dependent
7. 6 only with fitted preparation for engine start-stop under the front flap/frame end

Should you have any queries on the above, please contact Sales Engineering on 01793 448000 or Email Salesengineering@man.eu

Please circulate and then retain in the Body Builders Manual.

The MAN part numbers for the X6493 (White) connector are below. If you are intending to add wires into the existing empty plug then only choose a Blade terminal base for the wire size. If you want to build a loom to plug into the vehicle, you will need the connector body and the secondary lock

Contacts X6493	MAN Part No
Blade Terminal up to 1.5mm wire size	07.91201-0644
Blade Terminal for 1.5 to 5mm wire size	07.91201-0643
Matting connector (body)	81.25432-0540
Secondary lock for housing	81.25435-0973

Should you have any queries on the above, please contact Sales Engineering on 01793 448000 or Email Salesengineering@man.eu

Please circulate and then retain in the Body Builders Manual.