



# TGX Cab Specifications

Trucknology<sup>®</sup> delivers



# TGX Cab Dimensions

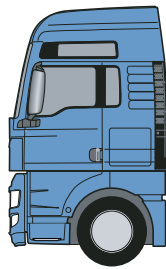

'XXL' Sleeper

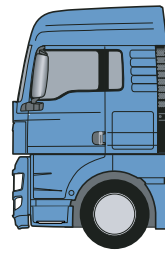

'XLX' Sleeper

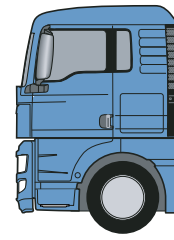

'XL' Sleeper

## TGX - 'XXL' International Long-haul Sleeper

A Overall cab height:	
- Without air management	3,771 mm
- With air management in low position	3,911 mm
- With air management in high position	4,111 mm
B Front overhang	1,475 mm
C Standing height from engine tunnel	2,190 mm
D Top bunk to roof	690 mm
E Bottom bunk to top bunk	790 mm
F Exterior cab width over doors	2,440 mm
G Exterior cab length	2,280 mm
H Interior cab length	2,145 mm
I Bunk length - bottom	2,205 mm
Bunk length - top	2,125 mm
J Bunk width - bottom	790 mm
Bunk width - top	705 mm
K Interior cab width	2,256 mm

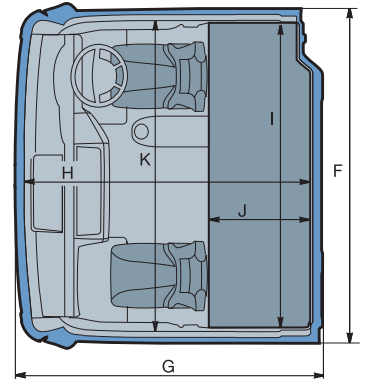
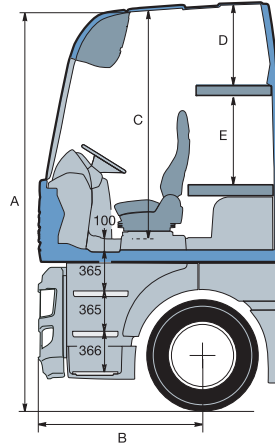

## TGX - 'XLX' International / National Long-haul Sleeper

A Overall cab height:	
- Without air management	3,546 mm
- With air management in low position	3,895 mm
- With air management in high position	4,011 mm
B Front overhang	1,475 mm
C Standing height from engine tunnel	1,875 mm
D Top bunk to roof	555 mm
E Bottom bunk to top bunk	690 mm
F Exterior cab width over doors	2,440 mm
G Exterior cab length	2,280 mm
H Interior cab length	2,145 mm
I Bunk length - bottom	2,205 mm
Bunk length - top	2,125 mm
J Bunk width - bottom	790 mm
Bunk width - top	705 mm
K Interior cab width	2,256 mm

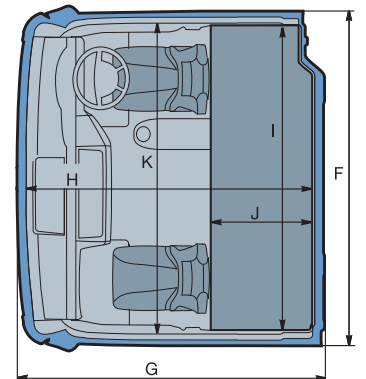
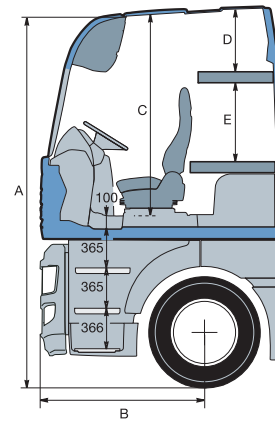

## TGX - 'XL' National Long-haul Sleeper

A Overall cab height:	
- Without air management	3,248 mm
- With air management in low position	3,748 mm
- With air management in high position	3,946 mm
B Front overhang	1,475 mm
C Standing height from engine tunnel	1,560 mm
E Bottom bunk to roof	1,025 mm
F Exterior cab width over doors	2,440 mm
G Exterior cab length	2,280 mm
H Interior cab length	2,145 mm
I Bunk length - bottom	2,205 mm
J Bunk width - bottom	790 mm
K Interior cab width	2,256 mm

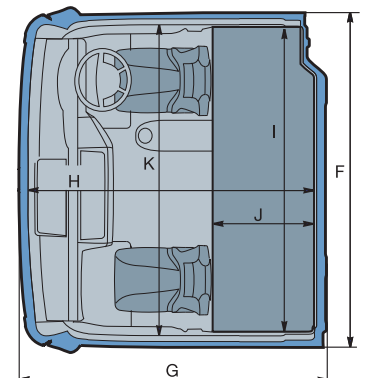
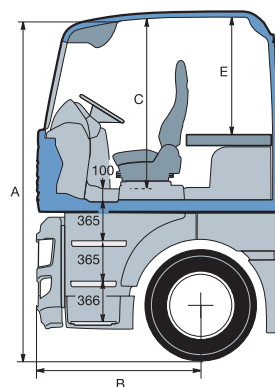

Above height dimensions are based on unladen chassis with 315/70R22.5 tyres (add 16mm for 295/80R22.5 tyres).

# TGX Equipment

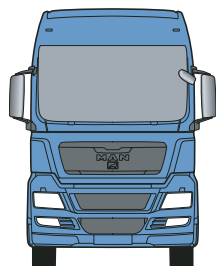

'XXL' Sleeper

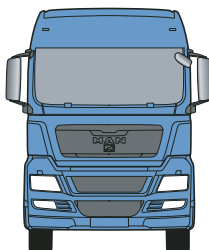

'XLX' Sleeper

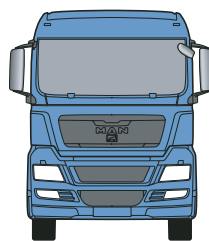

'XL' Sleeper



## TGX Standard Equipment

### Exterior

- Cab colour (incl bumper, door extensions, wings) - Pure white RAL 9010
- Electrically adjustable and heated rear view & wide angle mirrors
- Kerb view and front mounted mirrors
- 4 point cab air suspension system
- Hydraulic tilt to 65 degrees
- Automatic locking mechanism
- Underbumper air dam
- Mirror housings in same colour as cab
- Door extensions
- Front panel lockable from inside
- Roof hatch

### Interior

- Multifunction steering wheel
- Aluminium inlay in dashboard
- Digital tachograph
- Radio CD 24 volt (double DIN format)
- Adjustable steering column
- Internal rollerblind sun visors (electrically operated on XXL)
- Rubber floor covering
- Auxiliary 12/24 volt 2 pin sockets
- Full cab curtains
- High-Line instrument panel with driver information system for all major functions
- Single bunk (XL model)
- Twin bunk (XLX & XXL models)
- Clock with alarm function at bunk
- Remote control central locking
- Ambiance interior lighting
- Waste bin between seats

### Safety

- Entry lighting for driver and co-driver
- External temperature display
- LED parking lights
- LED roof marker lights
- Non slip entry steps
- Light test function
- Sunblind on drivers door
- Headlight washer system
- Safety belt display

### Storage

- Underbunk storage
- 2 large external storage lockers - one accessible from inside
- Header rail storage
- Pull out centre storage box with folding table (XLX & XXL models)
- Storage pockets with bottle holder in both doors
- Overhead storage lockers (XLX & XXL models)
- Centre console with pocket for spectacles and pen holder
- 2 drawers in centre console
- Rubberised trays on dashboard
- Storage pocket in door armrest

### Heating & Ventilation

- Heating system with variable fan speed control
- Air conditioning with automatic temperature control
- Night heater
- Nordic cab insulation package

### Seats

- High comfort driver seat with air suspension, lumbar support, shoulder adjustment and heating
- Armrests for driver seat
- Adjustable highback co-driver seat

### Windows

- Electric driver and passenger door windows
- Tinted windscreen, laminated glass
- Tinted door and side windows

## TGX Optional Equipment

S = Standard O = Optional

### Exterior

	XL	XLX	XXL
Adjustable air management kit with side deflectors (4x2 & 6x2 Tractors)	S	S	S
Adjustable air management kit with side deflectors (Drawbars)	O	O	O
Adjustable roof spoiler	O	O	O
Memory function for external mirrors	O	O	O
CB radio antenna on cab roof	O	O	O
External sun visor (Grey)	O	O	O
2 air horns on cab roof	O	O	O
Antenna for GPS and mobile phone	O	O	O
3-part steel bumper (Not colour co-ordinated with cab)	O	O	O
Electric roof hatch	O	O	S
Electric/hydraulic cab tilt	O	O	S

### Interior

	XL	XLX	XXL
Burr walnut dashboard trim	O	O	O
Carbon inlay dashboard trim	O	O	O
Foot rest for co-driver	O	O	O
Radio Top Line with navigation unit	O	O	O
Remote control for radio	O	O	O
MAN sound system	O	O	S
MAN CD autochanger	O	O	O
Luxury bunk(s)	O	O	O
Sunblind on both doors	O	O	O
Window / Sliding roof control at top bunk	-	O	S
Leather interior	O	O	O

### Safety

	XL	XLX	XXL
Combined fog and spot lights (Steel bumper only)	O	O	O
Combined fog, spot and turning lights (Synthetic bumper only)	O	O	S
Shunting light	O	O	O
Fire extinguisher	O	O	O
Electrical prep for hands free phone	O	O	O
Lane guard system (LGS)	O	O	O
Electronic Stability Programme (ESP) (standard on 4x2 tractors)	O	O	O

### Storage

	XL	XLX	XXL
Pull out centre storage box	O	S	S
Folding table on pull out storage box	O	S	S
Pull out coolbox with active cooling	O	O	O

### Seats

	XL	XLX	XXL
Driver seat with climate control	O	O	O
Reclining co-driver seat	-	-	O
Air suspended co-driver seat	O	O	O
Armrests for co-driver seat	O	O	O
Leather seats	O	O	O

---

MAN Truck & Bus UK Ltd.,  
Frankland Road, Blagrove,  
Swindon. Wiltshire SN5 8YU  
[www.mantruckandbus.co.uk](http://www.mantruckandbus.co.uk)

Ref: MAN TGX Cab / 03  
Issue Date: April 2011  
Technical illustrations are not binding.  
Subject to modifications in the course of progress.

