

TGX 18.360 4x2 LLS-U Low Height Tractor TGX 18.400 4x2 LLS-U Low Height Tractor TGX 18.440 4x2 LLS-U Low Height Tractor

Chassis Specification

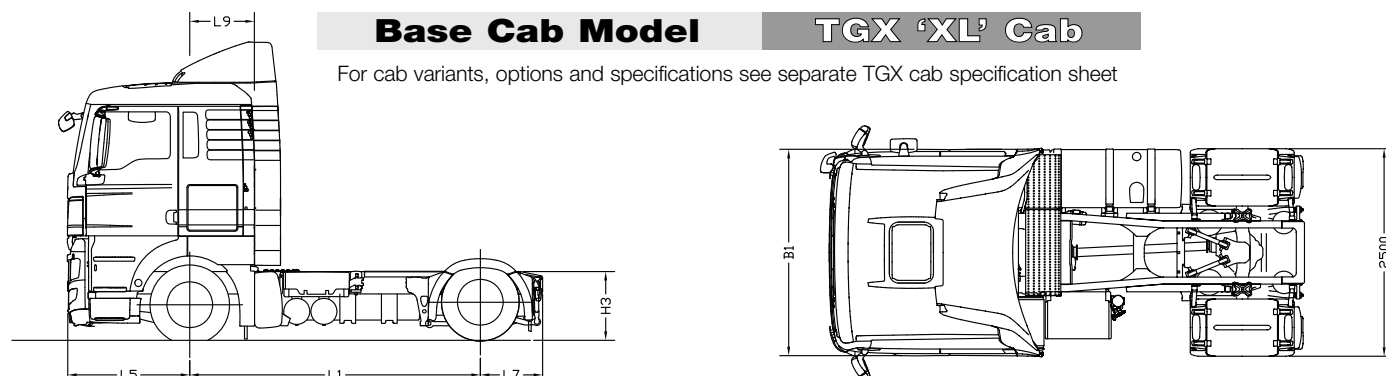

Base Cab Model

TGX 'XL' Cab

For cab variants, options and specifications see separate TGX cab specification sheet

Vehicle Dimensions (mm)

| | | |
|-----------|--|-------------|
| L1 | Wheelbase | 3500 |
| L5 | Front overhang | 1475 |
| L7 | Rear overhang | 750 |
| L9 | Centre line front axle to back of cab | 805 |
| B1 | Width across wings | 2490 |
| H3 | Frame height at centre rear wheels - laden | 808 |
| | - unladen | 838 |

Turning Circle

| | | |
|-----|---|-------|
| WTW | Wall to Wall | 14600 |
| KTK | Kerb to Kerb | 12700 |
| | Optimum 5th wheel position for standard specification | 485 |

Unladen Weights (kg +/- 2.5%)

| | |
|------------|------|
| Front axle | 5245 |
| Rear axle | 2105 |
| Total | 7350 |

N.B. Unladen weights are for vehicle in standard specification with full tank of fuel, AdBlue and without driver.

Plated/Operating Weights (kg)

| | Design | UK Legal |
|------------------------------|--------|----------|
| GCW Gross Combination Weight | 44000 | 40000 |
| GVW Gross Vehicle Weight | 18000 | 18000 |
| Front axle | 7500 | 7100 |
| Rear axle | 11500 | 11500 |

N.B. Tyre changes can effect legal weights.

Optional Equipment & Weights (kg)

| | Front | Rear | Total | | Front | Rear | Total |
|--------------------------------|-------|------|-------|---|-------|------|-------|
| Dual height fifth wheel | +45 | +291 | +336 | 'XLX' Sleeper cab | +40 | 0 | +40 |
| 16 Speed manual gearbox | +45 | +20 | +65 | 'XXL' Sleeper cab | +85 | 0 | +85 |
| ZF PTO NH/4 | +4 | +3 | +7 | ADR Preparation | +40 | 0 | +40 |
| Alloy Air Tanks | -6 | -4 | -10 | All weights indicated above are subject to +/- 2.5% manufacturer's tolerance. | | | |
| 9.00 x 22.5 Alcoa Alloy Wheels | -38 | -76 | -114 | | | | |
| 225 Ah Batteries | +30 | 0 | +30 | | | | |

TGX 18.360 4x2 LLS-U Low Height Tractor TGX 18.400 4x2 LLS-U Low Height Tractor TGX 18.440 4x2 LLS-U Low Height Tractor



Chassis Specification

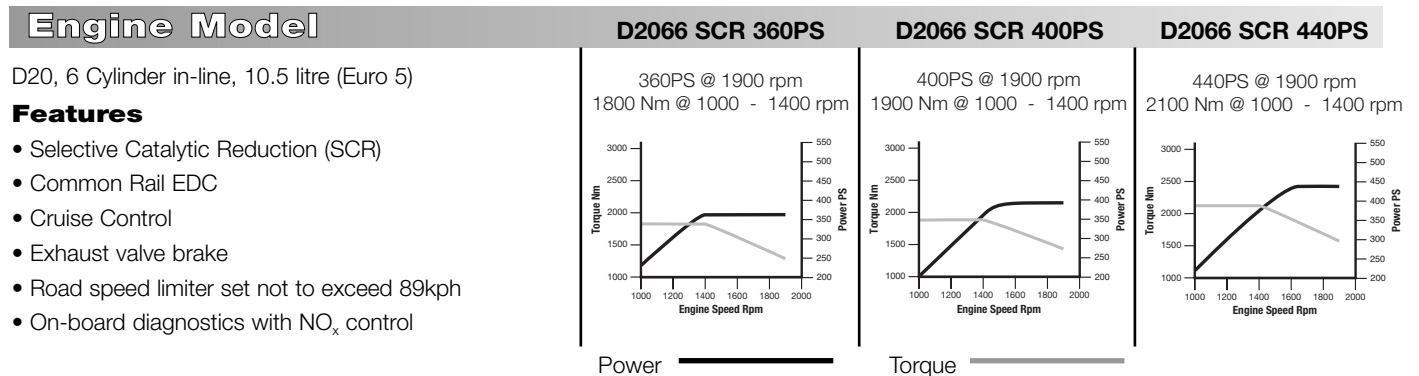

| Performance | | | | | | | | @40000 kg |
|--------------|-------------|------------|-------------------------|--------------------|--------------------|----------------|-------------|-----------|
| Engine Power | Gearbox | Axle Ratio | Geared Road Speed (mph) | Engine RPM @55 mph | Engine RPM @50 mph | Starting Grade | Tyre Size | |
| 360PS | 12AS2130 DD | 2.71:1 | 73 | 1425 | 1295 | 33%+ | 295/60R22.5 | |
| 400PS | 12AS2130 DD | 2.71:1 | 73 | 1425 | 1295 | 33%+ | 295/60R22.5 | |
| 440PS | 12AS2130 DD | 2.71:1 | 73 | 1425 | 1295 | 33%+ | 295/60R22.5 | |

Clutch

Single plate 430mm diameter, non asbestos

Gearbox

MAN Tipmatic 12 speed automated gearbox

Ratios

| Forward | 1 | 15.86 | 2 | 12.33 | 3 | 9.57 |
|---------|------|-------|------|-------|------|------|
| 4 | 7.44 | 5 | 5.87 | 6 | 4.57 | |
| 7 | 3.47 | 8 | 2.70 | 9 | 2.10 | |
| 10 | 1.63 | 11 | 1.29 | 12 | 1.00 | |

Reverse
14.68

Manual Gearbox Options

16 speed gearbox, with range change and splitter.

Frame

| | |
|--------------|---------------------------------------|
| Construction | Bolted and Riveted |
| Material | High tensile steel |
| Section | 270 x 85 x 8mm 940 - 762mm waisted |

Fuel Tank

| | |
|----------|--|
| Capacity | 595 Litre |
| Section | Rectangular Aluminium with Integral Step RHS mounted Locking cap |

Axles

| | |
|-------|--------------------------|
| Steer | VOK-08 drop beam |
| Drive | HY-1350 single reduction |

Suspension

| | |
|------------|---|
| Steer Axle | ECAS Controlled 2 Bag Air Hydraulic Dampers |
| Drive Axle | ECAS Controlled 4 Bag Air Hydraulic Dampers Stabiliser |

Wheels & Tyres

| | | |
|------------|--------|--------------------------------|
| Steer Axle | Tyres | 315/60R 22.5 steer tread |
| | Wheels | 9.00x22.5 |
| Drive Axle | Tyres | 295/60R 22.5 traction tread |
| | Wheels | 9.00x22.5 |

Electrical System

| | |
|------------|---|
| Type | MANTronic CAN bus system with central on board computer and vehicle management computer |
| Voltage | 24v |
| Alternator | 120 Amp |
| Batteries | 2 x 12v 175Ah |

Braking System

| | |
|---------------|--|
| Type | Electronic Brake System (EBS) with Anti-lock Braking System (ABS) and ASR traction control |
| Features | Vented disc brakes, 2 line trailer brake connections and pad wear indicators |
| Parking Brake | Spring brakes on rear axle |

Steering Gear

| | |
|------|--|
| Type | ZF 8098 Servocom hydraulically assisted. |
|------|--|

Exhaust System

Ground discharge silencer.

General Equipment

- Adjustable roof blade air management with cab side deflectors
- 3 piece plastic rear wings and spray reduction mats
- Catwalk
- Hoses and couplings including ABS lead
- Coupling lamp
- Rear axle diff lock
- 70 litre AdBlue tank
- Remote control central locking
- Heated Separ water trap
- Telemetry interface module

TGX 18.360 4x2 LLS-U Low Height Tractor
TGX 18.400 4x2 LLS-U Low Height Tractor
TGX 18.440 4x2 LLS-U Low Height Tractor

Cab Options

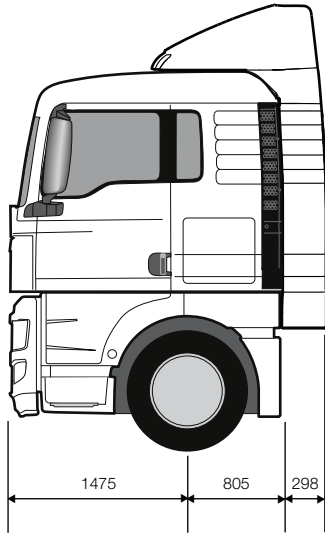

'XL' Sleeper - Standard
Additional weight: 0 kg

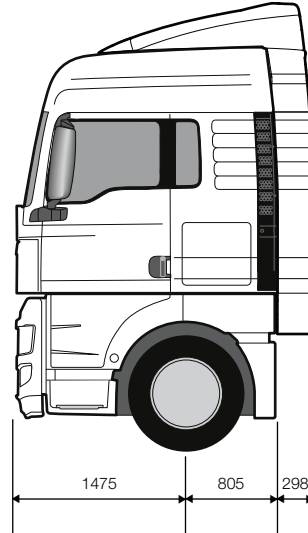

'XLX' Sleeper
Additional Weight: 40 kg

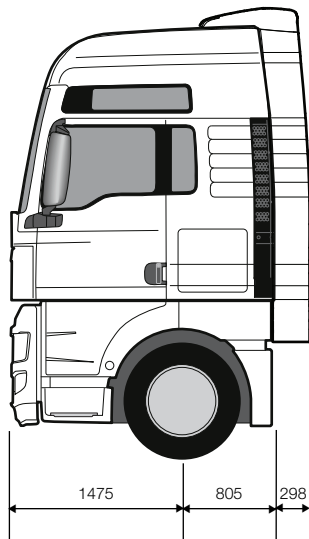

'XXL' Sleeper
Additional Weight: 85 kg

MAN Truck & Bus UK Ltd.,
Frankland Road, Blagrove,
Swindon. Wiltshire SN5 8YU
www.mantruckandbus.co.uk

