



TGS Cab Specifications

Trucknology® delivers



TGS Cab Dimensions



'LX' Sleeper

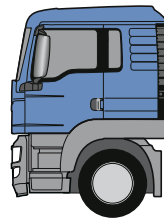

'L' Sleeper

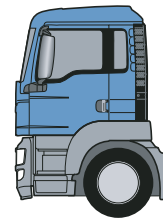

'M' Day

TGS - 'LX' Distribution Sleeper

A Overall cab height:	
- Without air management	3,384 mm
- With air management in low position	3,859 mm
- With air management in high position	4,057 mm
B Front overhang	1,475 mm
C Standing height from engine tunnel	1,645 mm
D Top bunk to roof (Optional)	575 mm
E Bottom bunk to top bunk	590 mm
F Exterior cab width over doors	2,240 mm
G Exterior cab length	2,280 mm
H Interior cab length	2,145 mm
I Bunk length - bottom	2,005 mm
Bunk length - top	2,005 mm
J Bunk width - bottom	750 mm
Bunk width - top	700 mm
K Interior cab width	2,056 mm

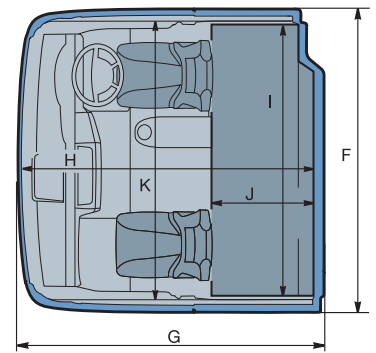
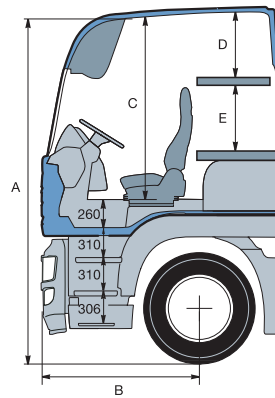

TGS - 'L' Distribution Sleeper

A Overall cab height:	
- Without air management	3,078 mm
- With air management in low position	3,572 mm
- With air management in high position	3,770 mm
B Front overhang	1,475 mm
C Standing height from engine tunnel	1,385 mm
E Bottom bunk to roof	923 mm
F Exterior cab width over doors	2,240 mm
G Exterior cab length	2,280 mm
H Interior cab length	2,145 mm
I Bunk length - bottom	2,005 mm
J Bunk width - bottom	750 mm
K Interior cab width	2,056 mm

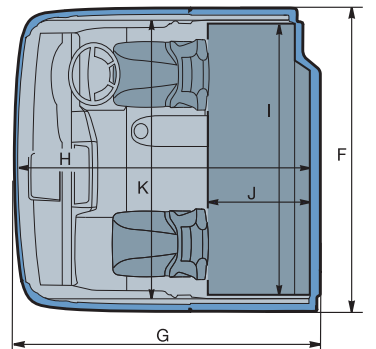
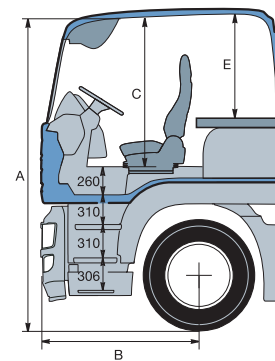

TGS - 'M' Distribution Day

A Overall cab height:	
- Without air management	3,078 mm
- With air management in low position	3,633 mm
- With air management in high position	3,858 mm
B Front overhang	1,475 mm
C Standing height from engine tunnel	1,385 mm
F Exterior cab width over doors	2,240 mm
G Exterior cab length	1,880 mm
H Interior cab length	1,770 mm
K Interior cab width	2,056 mm

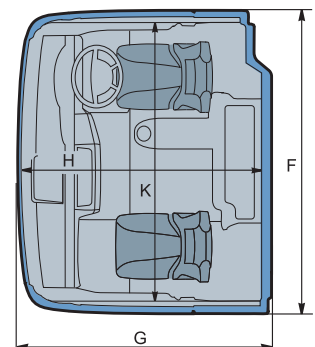
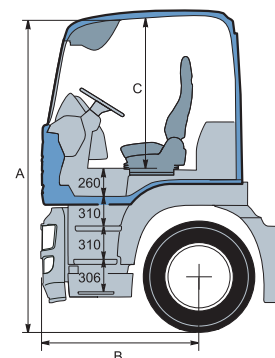

Above height dimensions are based on unladen chassis with 315/70R22.5 tyres (add 16mm for 295/80R22.5 tyres).

TGS Equipment



'LX' Sleeper

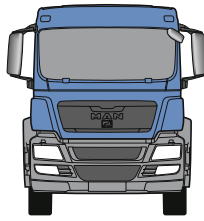

'L' Sleeper

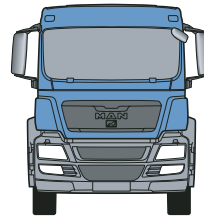

'M' Day



TGS Standard Equipment

Exterior

- Cab colour - Pure white RAL 9010
- Electrically adjustable and heated rear view & wide angle mirrors
- Kerb view and front mounted mirrors
- 4 point cab suspension system, air suspended at rear (tractor sleeper models)
- Cab mounts on coil springs (all rigid and M cab models)
- Hydraulic tilt to 65 degrees
- Automatic locking mechanism
- Underbumper air dam
- Front panel lockable from inside
- Roof hatch

Interior

- Multifunction steering wheel (sleeper models)
- Aluminium inlay in dashboard
- Digital tachograph
- Radio CD 24 volt (double DIN format)
- Adjustable steering column
- Internal rollerblind sun visors
- Rubber floor covering
- Auxiliary 12/24 volt 2 pin sockets
- Base-Line instrument panel with driver information system for all major functions
- Single bunk (sleeper models)
- Full cab curtains (sleeper models)
- Central door locking
- Waste bin between seats
- Door interior panelling washable

Safety

- Entry lighting for driver and co-driver
- External temperature display
- LED parking lights
- Non slip entry steps
- Light test function
- Sunblind on drivers door
- High visibility (Red) seat belts (not 8x4s)
- Safety belt display

Storage

- Underbunk storage (sleeper models)
- 2 large external storage lockers - one accessible from inside (sleeper models)
- Header rail storage
- Storage pockets with bottle holder in both doors
- Overhead storage lockers (LX model)
- Centre console with pocket for spectacles and pen holder
- 1 drawer in centre console
- Rubberised trays on dashboard
- Multifunction storage/temporary bunk (LX model)

Heating & Ventilation

- Heating system with variable fan speed control
- Night heater (sleeper models)

Seats

- High comfort driver seat with air suspension, lumbar support, shoulder adjustment and heating
- High comfort driver seat with air suspension (8x4 models)
- Adjustable highback co-driver seat

Windows

- Electric driver and passenger door windows
- Tinted windscreen, laminated glass
- Tinted door and side windows

TGS Optional Equipment

S = Standard O = Optional

Exterior

	M	L	LX
Adjustable air management kit with side deflectors (4x2 & 6x2 Tractors)	-	S	S
Adjustable air management kit with side deflectors (Drawbars)	-	O	O
Adjustable roof spoiler	O	O	O
Memory function for external mirrors	O	O	O
CB radio antenna on cab roof	O	O	O
External sun visor (Grey)	O	O	O
2 air horns on cab roof	O	O	O
Antenna for GPS and mobile phone	O	O	O
* 3-part steel bumper	O	O	O
Electric roof hatch	O	O	O
Electric/hydraulic cab tilt	O	O	O
4 point cab air suspension system	O	O	O

Interior

Burr walnut dashboard trim	O	O	O
Foot rest for co-driver	O	O	O
Radio Top Line with navigation unit	O	O	O
Remote control for radio	O	O	O
MAN sound system	O	O	O
MAN CD autochanger	O	O	O
Sunblind on both doors	O	O	O
Window control at top bunk	-	-	O
Second bunk	-	-	O

Safety

Combined fog and spot lights (Steel bumper only)	O	O	O
Combined fog, spot and turning lights (Synthetic bumper only)	O	O	O
Shunting light	O	O	O
Fire extinguisher	O	O	O
Electrical prep for hands free phone	O	O	O
Lane Guard System (LGS)	O	O	O
Electronic Stability Programme (ESP) (standard on 4x2 tractors)	O	O	O

Storage

Pull out centre storage box	O	O	S
Folding table on pull out storage box	O	O	O
Pull out coolbox with active cooling	O	O	O

Heating & Ventilation

Air conditioning with automatic temperature control	O	O	O
Nordic cab insulation package	O	O	O

Seats

Driver seat with climate control	O	O	O
Air suspended co-driver seat	O	O	O
Armrests for driver seat	O	O	O
Armrests for co-driver seat	O	O	O

Windows

** 2 windows in rear cab wall	O	O	O
2 tinted windows in rear cab wall	O	O	O
Curtains at rear windows	O	O	-

* 3-part steel bumper standard on 8x4 models

** 2 windows in rear cab wall standard on M cab 8x4 models

MAN Truck & Bus UK Ltd.,
Frankland Road, Blagrove,
Swindon. Wiltshire SN5 8YU
www.mantruckandbus.co.uk

Ref: MAN TGS Cab / 03
Issue Date: April 2011
Technical illustrations are not binding.
Subject to modifications in the course of progress.

