



TGM 18 Tonne 4x2 Tipper

Chassis Specification: TGM 18.250 4x2 BB
TGM 18.290 4x2 BB



TGM 18.250 18 Tonne 4x2 BB Tipper TGM 18.290 18 Tonne 4x2 BB Tipper

Chassis Specification

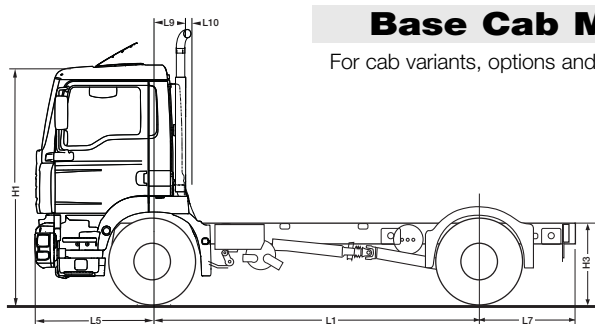

Base Cab Model

TGM C Cab

For cab variants, options and specifications see separate TGM cab specification sheet

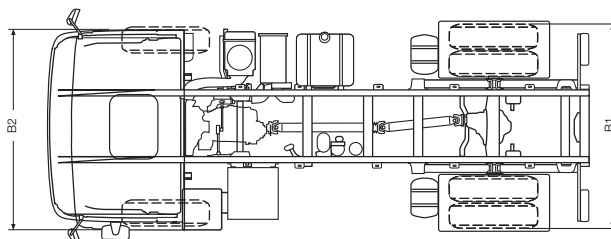

Vehicle Dimensions (mm)

Dimension	Base Cab Model	TGM C Cab
L1 Wheelbase	3575	3875
L5 Front overhang	1400	1400
L7 Rear overhang	1125	1125
L9 Centre line front axle to back of cab (including exhaust pipe)	480	480
L10 Back of cab to foremost body/equip. position	50	50
B1 Width across rear tyres	2422	2422
B2 Cab width over wings	2490	2490
H1 Cab height	- laden 2856 - unladen 2946	2856 2946
H3 Frame height at centre rear wheels	- laden 968 - unladen 1109	968 1109

Turning Circle

WTW Wall to Wall	14600	15500
KTK Kerb to Kerb	12900	13900

Unladen Weights (kg +/- 2.5%)

Front axle	3590	3620
Rear axle	1545	1575
Total	5135	5195

N.B. Unladen weights are for vehicle in standard specification with full tank of fuel and without driver.

Plated/Operating Weights (kg)

	Design	UK Legal
GTW Gross Train Weight	33000 ⁽¹⁾	33000 ⁽¹⁾
GVW Gross Vehicle Weight	18000	18000
Front axle	7100/7500 ⁽²⁾	7100/7500 ⁽²⁾
Rear axle	11500	11500

N.B. Tyre changes can effect legal weights. ⁽¹⁾ Maximum value, subject to specification.

⁽²⁾ Only with data conversion file, suspension and suitable tyres.

Optional Equipment & Weights (kg)

	Front	Rear	Total		Front	Rear	Total
290PS Engine In Lieu Of 250PS Engine	+10	0	+10	Document Box	+5	0	+5
Exhaust Valve Brake (EVB)	+7	0	+7	Steel Front Bumper	+14	-6	+14
140 Ah Batteries	+15	+5	+20	MAN Alloy Wheels 8.25x22.5	-30	-60	-90
Air Conditioning	+25	0	+25	EEV engine	+7	0	+7

All weights indicated above are subject to +/- 2.5% manufacturer's tolerance.

TGM 18.250 18 Tonne 4x2 BB Tipper TGM 18.290 18 Tonne 4x2 BB Tipper



Chassis Specification

Engine Model	D0836 LFL63 250 PS	D0836 LFL64 290 PS
6 Cylinder in-line, 6.9 litre (Euro 5)		
Features		
<ul style="list-style-type: none"> Exhaust Gas Recirculation (EGR) Common Rail EDC Cruise Control Exhaust brake Road speed limiter set to 89 kph On-board diagnostics with NO_x control Optional EEV engine 		
Maximum Power	250PS @ 2300 rpm	290PS @ 2300 rpm
Peak Torque	1000 Nm @ 1200-1750 rpm	1150 Nm @ 1200-1750 rpm
Graph Legend		
Power		
Torque		

Performance							@18000 kg
Engine Power	Gearbox	Axle Ratio	Geared Road Speed (mph)	Engine RPM @55 mph	Engine RPM @50 mph	Starting Grade	Tyre Size
250PS	9S1110 DD	3.70:1	74	1714	1558	33%+	295/80R22.5
290PS	9S1110 DD	3.70:1	74	1714	1558	33%+	295/80R22.5

Clutch
Single plate 395mm diameter, asbestos free lining

Axles
Steer VOK-08 drop beam
Drive HY-1133 single reduction drive axle with differential lock

Braking System
Type Electronic Brake System (EBS) with Anti-lock Braking System (ABS)
Features Disc brakes, air dryer, asbestos free linings and brake assistant
Parking Brake Spring brakes on rear axle

Gearbox
9S1110 DD 9 speed synchromesh gearbox
Ratios
1 12.73
2 8.83 3 6.28
4 4.64 5 3.48
6 2.54 7 1.81
8 1.34 9 1.00
R 12.04

Suspension
Steer Axle Parabolic Springs with Shock Absorbers and Stabiliser
Drive Axle Parabolic Springs with Shock Absorbers and Stabiliser

Steering Gear
Type ZF8098 Servocom hydraulically assisted.

Automated Gearbox Option
MAN Tipmatic 12 speed*
*Alternative axle ratio required.

Wheels & Tyres
Wheels Steel 8.25x22.5
Tyres Steel 295/80R 22.5 steer tread
Drive 295/80R 22.5 traction tread

Exhaust System
Vertical discharge silencer, incorporating diesel oxidation catalyst (DOC).

Frame
Construction Bolted and Riveted
Material High tensile steel
Section 270 x 70 x7mm
Frame Width 864mm
Front under run guard

Electrical System
Type MANTronic CAN bus system with central on board computer and vehicle management computer
Voltage 24v
Alternator 80 Amp
Batteries 2 x 12v 88Ah

General Equipment
Electronic immobiliser.
Fuel filter with water separator.
Manual door locking.
PTO without flange.
Audible reverse warning with night silent.
Manual mirrors.

Fuel Tank
Capacity 200 Litre
Section Rectangular Steel
RHS mounted with locking cap

TGM 18.250 18 Tonne 4x2 BB Tipper
TGM 18.290 18 Tonne 4x2 BB Tipper
Cab Options



'C' Day Cab - Standard
Additional weight: 0 kg

MAN Truck & Bus UK Ltd.,
Frankland Road, Blagrove,
Swindon. Wiltshire SN5 8YU
www.mantruckandbus.co.uk