



# TGM & TGL Cab Specifications

Trucknology® delivers



# TGM & TGL Cab Specifications



TGL 'C' Day



'L' Sleeper

## Cab Type - 'LX' Long-haul Sleeper

- Generous single bunk: Bottom: 2005 mm x 750 mm
- Multifunction storage/temporary bunk
- Headroom 1665 mm over engine tunnel
- Two large exterior storage lockers - one accessible from inside
- Driver Seat with air suspension, lumbar support and heating
- 2 point pneumatic cab suspension system
- Rollerblind sunvisors
- Pull out storage box
- Central locking

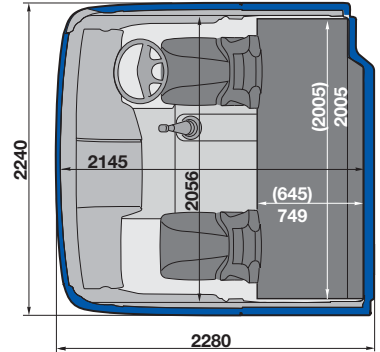
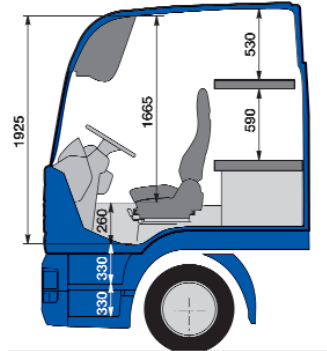

## Cab Type - 'L' Distribution Sleeper

- Generous single bunk - 2005 mm x 750 mm
- Headroom 1385 mm over engine tunnel
- Two large exterior storage lockers - one accessible from inside
- 2 point pneumatic cab suspension system
- Rollerblind sunvisors
- Driver Seat with air suspension, lumbar support and heating
- Central locking

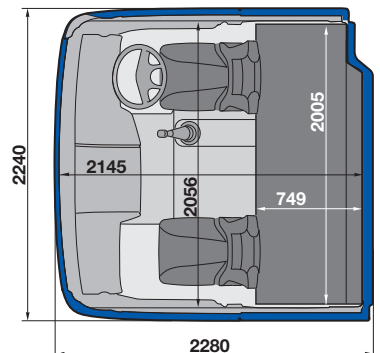
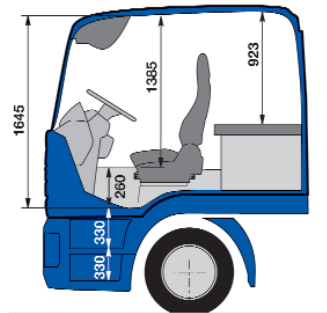

## Cab Type - 'DK' Crew Cab

- Driver Seat with air suspension
- 4 doors
- Manual roof hatch
- 2 point pneumatic cab suspension system
- 4 person bench seat to rear
- Folding sun visors
- Central locking (front doors)

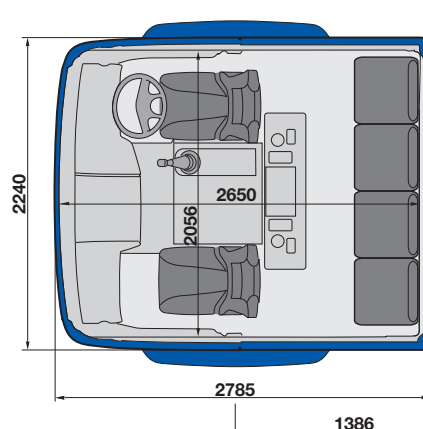
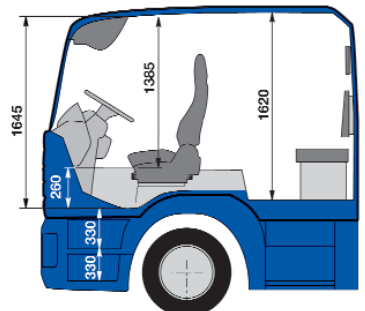

## Cab Type - 'C<sub>2</sub>' Distribution Day - Rigid

- Headroom 1309 mm over engine tunnel
- Driver Seat with air suspension (TGL and TGM Rigid models)
- Electric windows and Electric adjusting mirrors
- Mechanically sprung cab suspension system
- Folding sun visors
- Central locking

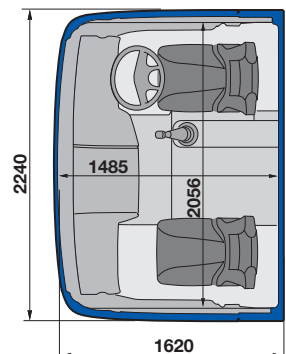
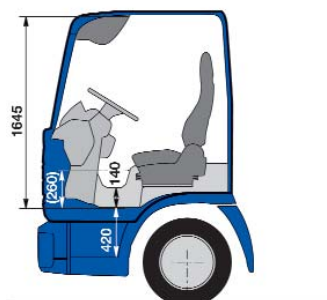

## Cab Type - 'C<sub>1</sub>' Distribution Day - All Tippers & 7.xxx Models

- Adjustable driver seat  
(standard on TGL 7.xxx and TGL Tipper models)
- Driver Seat with air suspension  
(standard on TGM Tipper models)
- Manual window winders and Manual rear-view mirrors
- Manual door locks



'LX' Sleeper



'DK' Cab



## Standard Equipment

### Exterior

Cab Colour - Pure white RAL 9010  
Rear view and wide angle mirrors  
Kerb and front view mirrors  
Mechanical cab suspension to rear  
Quarter panel air deflectors  
Hydraulic tilt to 65 degrees  
Underbumper air dam

### Interior

Digital tachograph  
Radio/CD 24v  
Adjustable steering column  
Internal folding sunvisor  
Rubber floor covering  
Auxiliary 12v/24v 2 pin sockets  
Soft trim roof liner  
Soft trim interior  
Washable door panels  
Cruise control  
Instrument panel with driver information system

### Safety

Seat belts for all seats  
Driver seatbelt warning audible and visual  
Head restraints for all seats  
Entry lighting  
Non slip entry steps

### Storage

Header rail storage  
Storage pockets in both doors  
Storage pockets on rear cab wall  
Under bunk storage (sleeper cab only)  
2 large external lockers - one accessible from inside (sleeper cabs only)

### Heating & Ventilation

Heating system with variable fan speed control

### Seats

Adjustable High back driver seat with cloth trim  
Adjustable High back co driver seat with cloth trim  
Dual passenger seat\*

### Windows

Laminated tinted windscreen  
3 Windows in rear cab wall tinted (Tipper models only)

## Optional Equipment

### Exterior

	C <sub>1</sub>	C <sub>2</sub>	L	LX	DK
Electrically adjustable & heated rear view mirrors	O	S	S	S	S
CB radio antenna	O	O	O	O	O
Antenna for GPS and mobile phone	O	O	O	O	O
Twin air horns on cab roof	O	O	O	O	O
External sun visor	O	O	O	O	O
Steel front bumper	O	O	O	O	O
Adjustable roof spoiler	O	O	O	O	-
Air suspended cab mounts to rear	-	-	S	S	S

### Interior

Comfort electric package	O	S	S	S	S
Navigation system	O	O	O	O	O
Telephone system	O	O	O	O	O
Manual roof hatch	O	O	S	S	S
Electric Slide / tilt sunroof	-	-	O	O	-
Deluxe dash board	-	-	O	O	-
TV Table for dashboard	-	-	O	O	-
Socket in cab 24v - 15 Amp	O	O	O	O	O
Carpet on Engine tunnel	-	-	S	S	-
All round Curtain	-	-	S	S	-
Diagonal Curtain	-	-	S	S	-
Single bunk	-	-	S	S	-
Single bunk with multifunction storage	-	-	O	S	-
Twin bunks	-	-	-	O	-

### Safety

Combined fog and spot lamps	O	O	O	O	O
Xenon headlamps	O	O	O	O	O
Headlamp washer system	O	O	O	O	O
Fire extinguisher	O	O	O	O	O

### Storage

Storage box with writing desk	O	O	-	-	O
Pull out oddments box	-	-	O	S	-
Pull out fridge	-	-	O	O	-
Folding table on pull out oddments box/fridge	-	-	O	O	-

### Heating & Ventilation

Air conditioning with automatic temp control	O	O	O	O	O
Night heater	O	O	S	S	O

### Seats

Air suspended driver seat	O	S	-	-	S
Air suspended driver seat with lumbar support and heating	O	O	S	S	O
Luxury seat covers	O	O	S	S	O
Co driver bench seat	S*	O	-	-	S
Air suspended co driver seat	O	O	O	O	O
Air suspended co driver seat with lumbar support and heating	O	O	O	O	O

### Windows

Windows in rear of cab wall	S	O	O	O	O
Roller blind for windscreen	-	-	S	S	S
Roller blind for NS Door	O	O	O	O	O
Roller blind for OS Door	O	O	O	O	O

\* Standard on 7.5t models only.

S = Standard O = Optional C<sub>1</sub> = All Tippers & 7.xxx models C<sub>2</sub> = All other TGM / TGL models

---

MAN Truck & Bus UK Ltd.,  
Frankland Road, Blagrove,  
Swindon. Wiltshire SN5 8YU  
[www.mantruckandbus.co.uk](http://www.mantruckandbus.co.uk)

Ref: MAN TGM & TGL Cab / 06  
Issue Date: April 2011  
Technical illustrations are not binding.  
Subject to modifications in the course of progress.

