

TGX 26.440 6x2/2 BLS Midlift Tractor

TGX 26.480 6x2/2 BLS Midlift Tractor

TGX 26.540 6x2/2 BLS Midlift Tractor

Chassis Specification

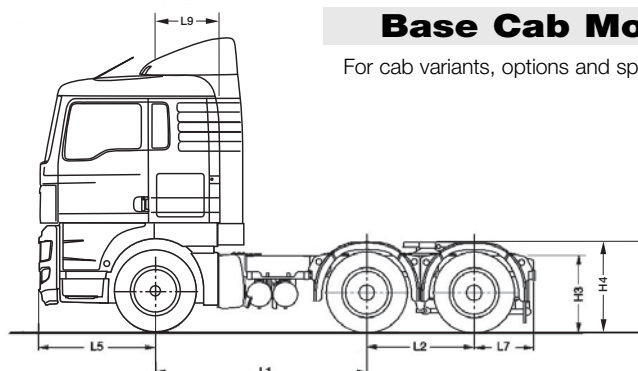

Base Cab Model

TGX 'XL' Cab

For cab variants, options and specifications see separate TGX cab specification sheet

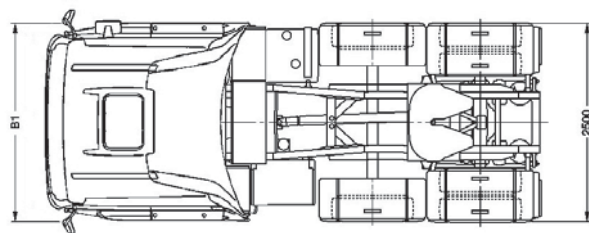

Vehicle Dimensions (mm)

L1	Wheelbase	2600	
L2	Rear bogie spread	1350	
L5	Front overhang	1475	
L7	Rear overhang	800	
L9	Centre line front axle to back of cab	805	
B1	Width across wings	2500	
H3	Frame height at centre rear wheels	- laden - unladen	961 991
H4	Standard 5th wheel height	- laden - unladen	1224 1254

Turning Circle

WTW	Wall to Wall	14800
KTK	Kerb to Kerb	13100
	Optimum 5th wheel position for standard specification	935

Unladen Weights (kg +/- 2.5%)

Front axle	5510
Rear axle	3065
Total	8175

N.B. Unladen weights are for vehicle in standard specification with full tank of fuel and without driver.

Plated/Operating Weights (kg)

	Design	UK Legal
GCW Gross Combination Weight	44000	40000 ⁽¹⁾ /44000 ⁽²⁾
GVW Gross Vehicle Weight	26000	23700
Front axle	8000	7500
Midlift axle	7100	7100 ⁽¹⁾ /6500 ⁽²⁾
Drive axle	11500	11500 ⁽¹⁾ /10500 ⁽²⁾

N.B. Tyre changes can effect legal weights. ⁽¹⁾@ 40000 kg or below ⁽²⁾above 40000 kg.

Optional Equipment & Weights (kg)

	Front	Rear	Total		Front	Rear	Total
D26 SCR Engine in lieu of D26 EGR engine (includes AdBlue)	+32	+33	+65	225 Ah Batteries	+30	0	+30
Fixed 5th wheel	+14	-63	-49	385/65R Super Single Tyres on 11.75x22.5 steel rims on front	+38	0	+38
16 Speed manual gearbox	+35	+30	+65	'XLX' Sleeper cab	+40	0	+40
ZF PTO NH/4	+4	+3	+7	'XXL' Sleeper cab	+85	0	+85
Alloy Air Tanks	-4	-11	-15	Lead up ramps	-7	+33	+26
9.00 x 22.5 Alcoa Alloy Wheels	-38	-114	-152	ADR Preparation	+40	0	+40
3 piece steel bumper	+89	-25	+64	All weights indicated above are subject to +/- 2.5% manufacturer's tolerance.			

TGX 26.440 6x2/2 BLS Midlift Tractor TGX 26.480 6x2/2 BLS Midlift Tractor TGX 26.540 6x2/2 BLS Midlift Tractor



Chassis Specification

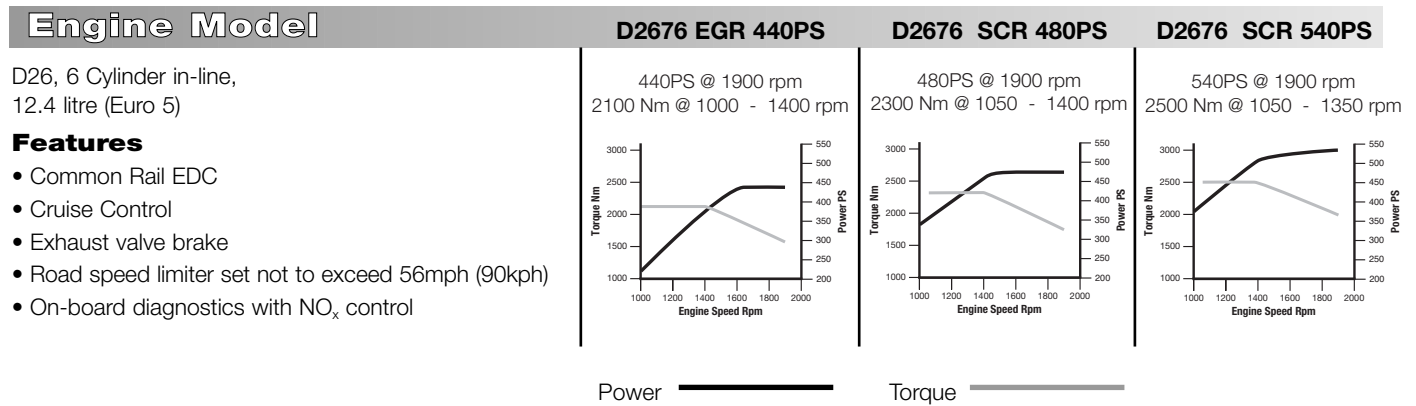

Performance							@44000 kg
Engine Power	Gearbox	Axle Ratio	Geared Road Speed (mph)	Engine RPM @55 mph	Engine RPM @50 mph	Starting Grade	Tyre Size
440PS	12AS2130 DD	2.85:1	77.0	1360	1236	33%+	315/70R22.5
480PS	12AS2330 DD	2.85:1	77.0	1360	1236	33%+	315/70R22.5
540PS	12AS2330 DD	2.85:1	77.0	1360	1236	33%+	315/70R22.5

Clutch

Single plate 430mm diameter, non asbestos

Axles

Steer	VOK-09 drop beam
Midlift Axle	LO-08 non steering
Drive Axle	HY-1350 single reduction

Braking System

Type	Electronic Brake System (EBS) with Anti-lock Braking System (ABS) and ASR traction control
Features	Vented disc brakes, 2 line trailer brake connections and pad wear indicators
Parking Brake	Spring brakes on rear axles

Gearbox

MAN Tipmatic 12 speed automated gearbox

Ratios

Forward					
1	15.86	2	12.33	3	9.57
4	7.44	5	5.87	6	4.57
7	3.47	8	2.70	9	2.10
10	1.63	11	1.29	12	1.00

Reverse
14.68

Suspension

Steer Axle	Parabolic Springs Hydraulic Dampers Stabiliser
Midlift Axle	2 Bag Air Hydraulic Dampers Air Operated Lift
Drive Axle	ECAS Controlled 4 Bag Air Hydraulic Dampers Stabiliser

Steering Gear

Type	ZF 8098 Servocom hydraulically assisted.
------	--

Manual Gearbox Options

16 speed gearbox, with range change and splitter.

Frame

Construction	Bolted and Riveted
Material	High tensile steel
Section	270 x 85 x 8mm 940 - 762mm waisted

Wheels & Tyres

Steer Axle	Tyres	315/70R 22.5 steer tread
	Wheels	9.00x22.5
Midlift Axle	Tyres	315/70R 22.5 steer tread
	Wheels	9.00x22.5
Drive Axle	Tyres	315/70R 22.5 drive tread
	Wheels	9.00x22.5

Exhaust System

Ground discharge silencer.

Fuel Tank

Capacity	450 Litre
Section	Rectangular Aluminium with Integral Step RHS mounted Locking cap

Electrical System

Type	MANTronic CAN bus system with central on board computer and vehicle management computer
Voltage	24v
Alternator	80 Amp
Batteries	2 x 12v 175Ah

General Equipment

- Adjustable roof blade air management with cab side deflectors
- Sliding fifth wheel and base plate
- 3 piece plastic rear wings and spray reduction mats
- Catwalk
- Hoses and couplings including ABS lead
- Coupling lamp
- Rear axle diff lock
- 35 litre AdBlue tank (SCR models only)

TGX 26.440 6x2/2 BLS Midlift Tractor
TGX 26.480 6x2/2 BLS Midlift Tractor
TGX 26.540 6x2/2 BLS Midlift Tractor
Cab Options

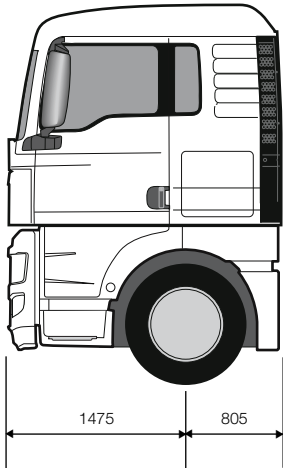

'XL' Sleeper - Standard
Additional weight: 0 kg

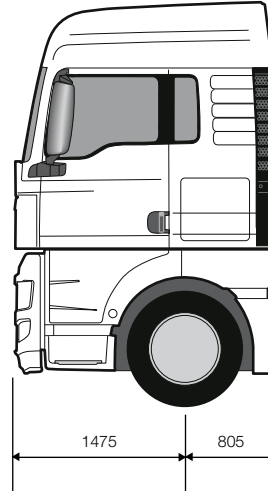

'XLX' Sleeper
Additional Weight: 40 kg

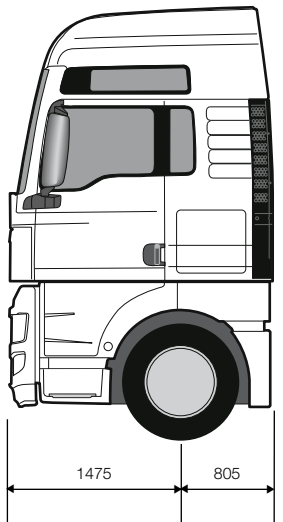

'XXL' Sleeper
Additional Weight: 85 kg

MAN Truck & Bus UK Ltd.,
Frankland Road, Blagrove,
Swindon. Wiltshire SN5 8YU
www.man-mn.co.uk

A member of the MAN Group.

