



## **TGS 4x2 Tractor**

**Chassis Specification:** TGS 18.360 4x2 BLS  
EURO 5 TGS 18.400 4x2 BLS  
TGS 18.440 4x2 BLS

# TGS 18.360 4x2 BLS Tractor TGS 18.400 4x2 BLS Tractor TGS 18.440 4x2 BLS Tractor

## Chassis Specification

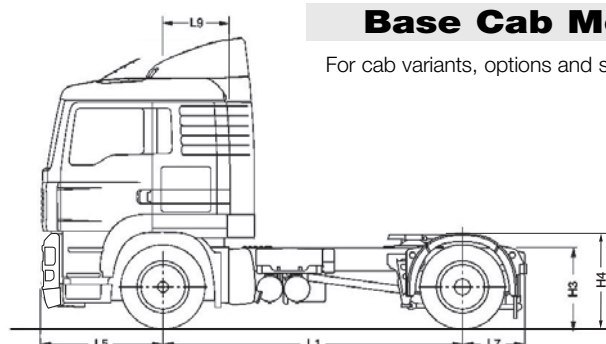

### Base Cab Model

### TGS 'L' Cab

For cab variants, options and specifications see separate TGS cab specification sheet

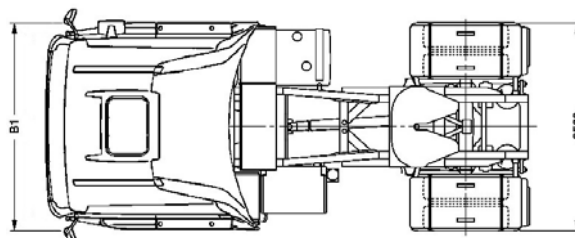

### Vehicle Dimensions (mm)

Dimension	Description	3600	3900
L1	Wheelbase	3600	3900
L5	Front overhang	1475	1475
L7	Rear overhang	800	800
L9	Centre line front axle to back of cab	805	805
B1	Width across wings	2500	2500
H3	Frame height at centre rear wheels	- laden: 942 - unladen: 972	- laden: 942 - unladen: 972
H4	Standard 5th wheel height	- laden: 1227 - unladen: 1257	- laden: 1227 - unladen: 1257

### Turning Circle

WTW	Wall to Wall	14800	15700
KTK	Kerb to Kerb	13100	14000
	Optimum 5th wheel position for standard specification	585	885

### Unladen Weights (kg +/- 2.5%)

Front axle	4865	4865
Rear axle	1935	1950
Total	6800	6815

N.B. Unladen weights are for vehicle in standard specification with full tank of fuel and without driver.

### Plated/Operating Weights (kg)

	Design	UK Legal
GCW Gross Combination Weight	44000	40000
GVW Gross Vehicle Weight	18000	18000
Front axle	7500	7100
Rear axle	11500	11500

N.B. Tyre changes can effect legal weights.

### Optional Equipment & Weights (kg)

	Front	Rear	Total		Front	Rear	Total
D26 EGR Engine in lieu of D20 EGR engine	+25	0	+25	Door extensions	+12	0	+12
Sliding 5th wheel	-10	+59	+49	Air Conditioning	+40	0	+40
16 Speed manual gearbox	+45	+20	+65	'M' Day cab	-225	0	-225
ZF PTO NH/4	+4	+3	+7	'LX' Sleeper cab	+20	0	+20
Alloy Air Tanks	-6	-4	-10	Lead up ramps	-3	+29	+26
Windows in rear cab wall	+8	0	+8	Side skirts based on 3900mm wheelbase	+28	+28	+56
9.00 x 22.5 Alcoa Alloy Wheels	-38	-76	-114	ADR Preparation	+40	0	+40
3 piece steel bumper	+88	-24	+64	All weights indicated above are subject to +/- 2.5% manufacturer's tolerance.			
225 Ah Batteries	+30	0	+30				

# TGS 18.360 4x2 BLS Tractor TGS 18.400 4x2 BLS Tractor TGS 18.440 4x2 BLS Tractor



## Chassis Specification

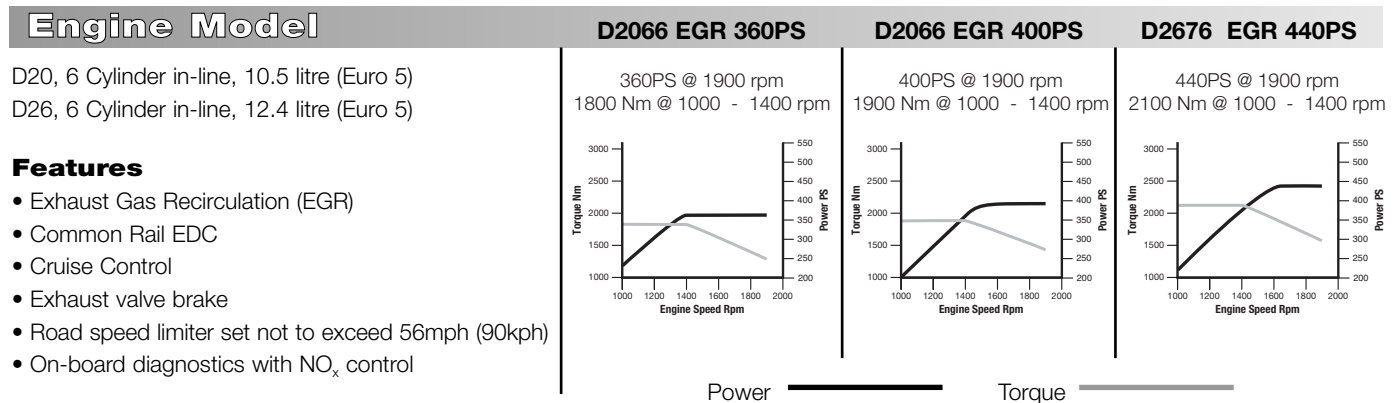

Performance							<b>@40000 kg</b>
Engine Power	Gearbox	Axle Ratio	Geared Road Speed (mph)	Engine RPM @55 mph	Engine RPM @50 mph	Starting Grade	Tyre Size
360PS	12AS2130 DD	3.08:1	69.2	1510	1372	33%+	295/80R22.5
400PS	12AS2130 DD	2.85:1	74.8	1397	1270	33%+	295/80R22.5
440PS	12AS2130 DD	2.85:1	74.8	1397	1270	33%+	295/80R22.5

### Clutch

Single plate 430mm diameter, non asbestos

### Gearbox

MAN Tipmatic 12 speed automated gearbox

Ratios

Forward	1	15.86	2	12.33	3	9.57
	4	7.44	5	5.87	6	4.57
	7	3.47	8	2.70	9	2.10
	10	1.63	11	1.29	12	1.00

Reverse  
14.68

### Manual Gearbox Options

16 speed gearbox, with range change and splitter.

### Frame

Construction	Bolted and Riveted
Material	High tensile steel
Section	270 x 85 x 8mm 940 - 762mm waisted

### Fuel Tank

Capacity	450 Litre
Section	Rectangular Aluminium with Integral Step RHS mounted Locking cap

### Axles

Steer	VOK-07 drop beam
Drive	HY-1350 single reduction

### Suspension

Steer Axle	Parabolic Springs with Shock Absorbers and Stabiliser
Drive Axle	ECAS Controlled 4 Bag Air Hydraulic Dampers 4-Point Control Arm

### Wheels & Tyres

Steer Axle	Tyres	295/80R 22.5 steer tread
	Wheels	9.00x22.5
Drive Axle	Tyres	295/80R 22.5 traction tread
	Wheels	9.00x22.5

### Electrical System

Type	MANTronic CAN bus system with central on board computer and vehicle management computer
Voltage	24v
Alternator	80 Amp
Batteries	2 x 12v 175Ah

### Braking System

Type	Electronic Brake System (EBS) with Anti-lock Braking System (ABS) and ASR traction control
Features	Vented disc brakes, 2 line trailer brake connections and pad wear indicators
Parking Brake	Spring brakes on rear axle

### Steering Gear

Type	ZF 8098 Servocom hydraulically assisted.
------	--

### Exhaust System

Ground discharge silencer

### General Equipment

Adjustable roof blade air management with cab side deflectors (sleeper models only)

Fixed fifth wheel and base plate

3 piece plastic rear wings and spray reduction mats

Catwalk

Hoses and couplings including ABS lead

Coupling lamp

Rear Axle diff lock

**TGS 18.360 4x2 BLS Tractor**  
**TGS 18.400 4x2 BLS Tractor**  
**TGS 18.440 4x2 BLS Tractor**

**Cab Options**

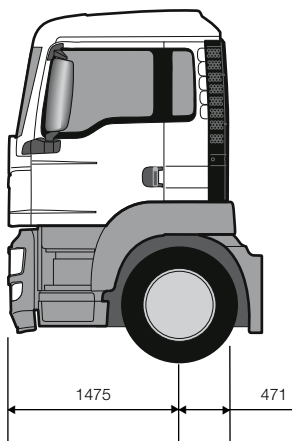

'M' Day Cab  
Additional weight: -225 kg

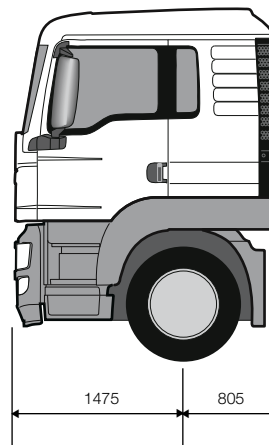

'L' Sleeper - Standard  
Additional Weight: 0 kg

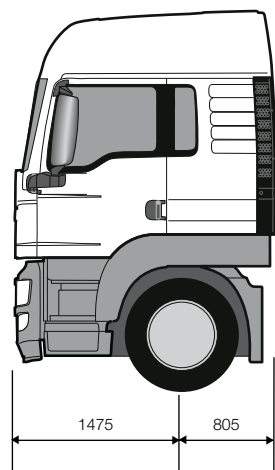

'LX' Sleeper  
Additional Weight: 20 kg

MAN Truck & Bus UK Ltd.,  
Frankland Road, Blagrove,  
Swindon. Wiltshire SN5 8YU  
[www.man-mn.co.uk](http://www.man-mn.co.uk)

**A member of the MAN Group.**

