



TGM & TGL Cab Specifications

Trucknology[®] delivers

MAN Truck & Bus UK Ltd.,
Frankland Road, Blagrove,
Swindon. Wiltshire SN5 8YU
www.man-mn.co.uk

A member of the MAN Group.

Ref: MAN TGM & TGL Cab / 05
Issue Date: Sept 2009
Technical illustrations are not binding.
Subject to modifications in the course of progress.



TGM & TGL Cab Specifications



TGL 'C' Day



'L' Sleeper



'LX' Sleeper



'DK' Cab

Cab Type - 'LX' Long-haul Sleeper

- Generous single bunk: Bottom: 2005mm x 749mm
- Multifunction storage/temporary bunk
- Headroom 1665mm over engine tunnel
- Two large exterior storage lockers - one accessible from inside
- Driver Seat with air suspension, lumbar support and heating
- 2 point pneumatic cab suspension system
- Rollerblind sunvisors
- Pull out storage box
- Central locking

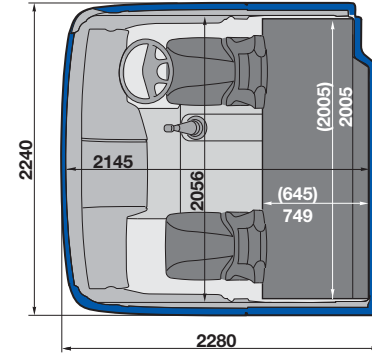
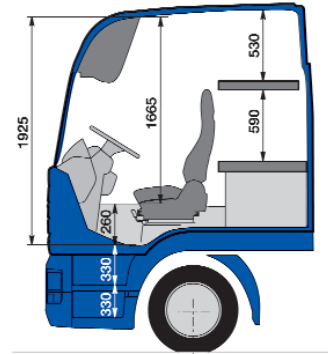

Cab Type - 'L' Distribution Sleeper

- Generous single bunk - 2005mm x 749mm
- Headroom 1385mm over engine tunnel
- Two large exterior storage lockers - one accessible from inside
- 2 point pneumatic cab suspension system
- Rollerblind sunvisors
- Driver Seat with air suspension, lumbar support and heating
- Central locking

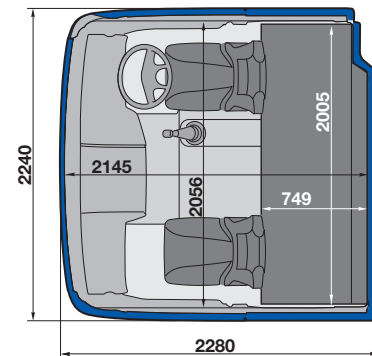
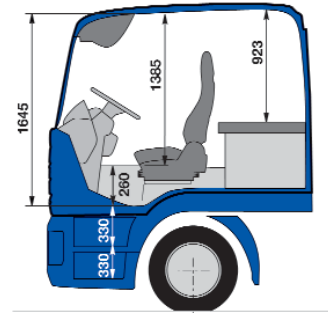

Cab Type - 'DK' Crew Cab

- Driver Seat with air suspension
- 4 doors
- Manual roof hatch
- 2 point pneumatic cab suspension system
- 4 person bench seat to rear
- Folding sun visors
- Central locking (front doors)

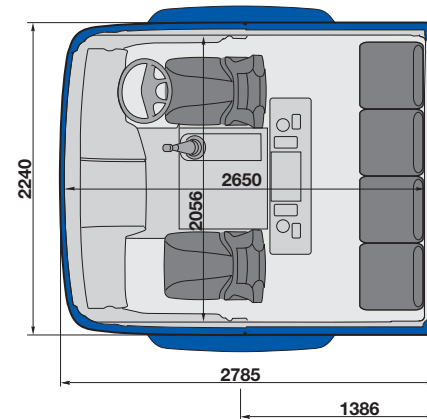
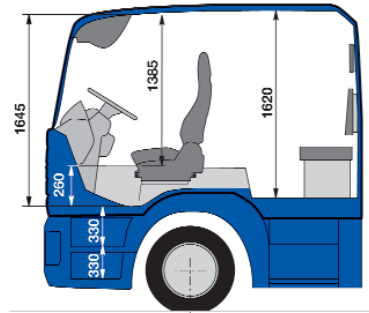

Cab Type - 'C₂' Distribution Day - Rigid

- Headroom 1309mm over engine tunnel
- Driver Seat with air suspension (TGL and TGM Rigid models)
- Electric windows and Electric adjusting mirrors
- Mechanically sprung cab suspension system
- Folding sun visors
- Central locking

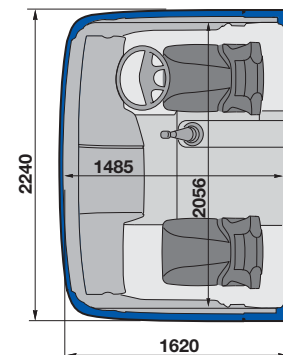
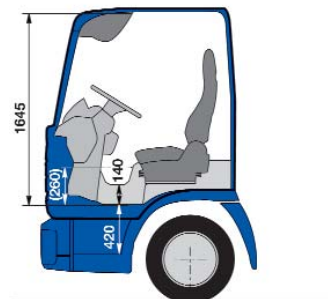

Cab Type - 'C₁' Distribution Day - All Tipper & 7.xxx Models

- Adjustable driver seat (standard on TGL 7.xxx and TGL Tipper models)
- Driver Seat with air suspension (standard on TGM Tipper models)
- Manual window winders and Manual rear-view mirrors
- Manual door locks

All dimensions are nominal and subject to change depending upon final TGM / TGL specification

Standard Equipment

Exterior

- Cab Colour - Pure white RAL 9010
- Rear view and wide angle mirrors
- Kerb and front view mirrors
- Mechanical cab suspension to rear
- Quarter panel air deflectors
- Hydraulic tilt to 65 degrees
- Underbumper air dam

Interior

- Digital tachograph
- Radio/CD 24v
- Adjustable steering column
- Internal folding sunvisor
- Rubber floor covering
- Auxiliary 12v/24v 2 pin sockets
- Soft trim roof liner
- Soft trim interior
- Washable door panels
- Cruise control
- Instrument panel with driver information system

Safety

- Seat belts for all seats
- Driver seatbelt warning audible and visual
- Head restraints for all seats
- Entry lighting
- Non slip entry steps

Storage

- Header rail storage
- Storage pockets in both doors
- Storage pockets on rear cab wall
- Under bunk storage (sleeper cab only)
- 2 large external lockers - one accessible from inside (sleeper cabs only)

Heating & Ventilation

- Heating system with variable fan speed control

Seats

- Adjustable High back driver seat with cloth trim
- Adjustable High back co driver seat with cloth trim
- Dual passenger seat (TGL 7.5t models only)

Windows

- Laminated tinted windscreen
- 3 Windows in rear cab wall tinted (Tipper models only)

Optional Equipment

Exterior

	C ₁	C ₂	L	LX	DK
Electrically adjustable & heated rear view mirrors	O	S	S	S	S
CB radio antenna	O	O	O	O	O
Antenna for GPS and mobile phone	O	O	O	O	O
Twin air horns on cab roof	O	O	O	O	O
External sun visor	O	O	O	O	O
Steel front bumper	O	O	O	O	O
Adjustable roof spoiler	O	O	O	O	-
Air suspended cab mounts to rear	-	-	S	S	S

Interior

Comfort electric package	O	S	S	S	S
Navigation system	O	O	O	O	O
Telephone system	O	O	O	O	O
Manual roof hatch	O	O	S	S	S
Electric Slide / tilt sunroof	-	-	O	O	-
Deluxe dash board	-	-	O	O	-
TV Table for dashboard	-	-	O	O	-
Socket in cab 24v - 15 Amp	O	O	O	O	O
Carpet on Engine tunnel	-	-	S	S	-
All round Curtain	-	-	S	S	-
Diagonal Curtain	-	-	S	S	-
Single bunk with pillow	-	-	S	S	-
Single bunk with multifunction storage	-	-	-	S	-
Twin bunks with pillows	-	-	-	O	-

Safety

Combined fog and spot lamps	O	O	O	O	O
Xenon headlamps	O	O	O	O	O
Headlamp washer system	O	O	O	O	O
Fire extinguisher	O	O	O	O	O

Storage

Storage box with writing desk	O	O	-	-	O
Pull out oddments box	-	-	O	S	-
Pull out fridge	-	-	O	O	-
Folding table on pull out oddments box/fridge	-	-	O	O	-

Heating & Ventilation

Air conditioning with automatic temp control	O	O	O	O	O
Night heater	O	O	S	S	O

Seats

Air suspended driver seat	O	S	-	-	S
Air suspended driver seat with lumbar support and heating	O	O	S	S	O
Luxury seat covers	O	O	S	S	O
Co driver bench seat (7.5t models only)	S	O	-	-	S
Air suspended co driver seat	O	O	O	O	O
Air suspended co driver seat with lumbar support and heating	O	O	O	O	O

Windows

Windows in rear of cab wall	S	O	O	-	O
Roller blind for windscreen	-	-	S	S	S
Roller blind for NS Door	O	O	O	O	O
Roller blind for OS Door	O	O	O	O	O

S = Standard O = Optional C₁ = TGL All Tipper & 7.xxx models C₂ = All other TGM / TGL models