

TGM 18 TONNE 4X2 RIGID

Chassis Specification:

TGM 18.250 4x2 BL CH

TGM 18.290 4x2 BL CH

TGM 18.320 4x2 BL CH



TGM 18 TONNE 4X2 RIGID

TGM 18.250 4x2 BL CH

TGM 18.290 4x2 BL CH

TGM 18.320 4x2 BL CH

Base Cab Model TGM 'CC' Cab

For cab variants, options and specifications see separate cab specification sheet.

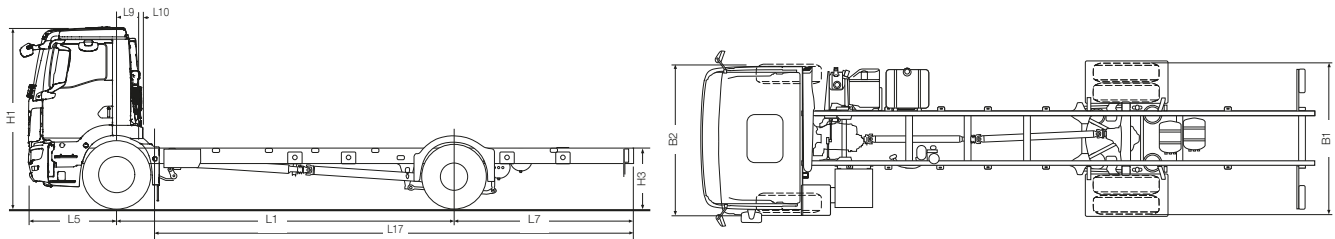

Vehicle Dimensions (mm)

L1	Wheelbase		4425	4725	5075	5425	5775	6175	6575	6975
L5	Front overhang		1400	1400	1400	1400	1400	1400	1400	1400
L7	Rear overhang		2325	2475	2675	2875	3075	3275	2675	2675
L9	Centre line front axle to back of cab		390	390	390	390	390	390	390	390
L10	Back of cab to start of body/equipment		50	50	50	50	50	50	50	50
L17	Min. recommended body length	mm	5559	6005	6519	7040	7553	8150	8748	9351
		ft.ins.	18'3"	19'8"	21'5"	23'1"	24'9"	26'9"	28'8"	30'8"
	Max. recommended body length	mm	5986	6463	7012	7568	8117	8755	8810	9210
		ft.ins.	19'8"	21'2"	23'0"	24'10"	26'8"	28'9"	28'11"	30'3"
B1	Width across rear tyres		2443	2443	2443	2443	2443	2443	2443	2443
B2	Cab width over wings		2488	2488	2488	2488	2488	2488	2488	2488
H1	Cab height	- laden	2873	2873	2873	2873	2873	2873	2873	2873
		- unladen	2949	2949	2949	2949	2949	2949	2949	2949
H3	Frame height at centre rear wheels	- laden	968	968	968	968	968	968	968	968
		- unladen	998	998	998	998	998	998	998	998

Recommended body length only applicable to bodies with UDL, without auxiliary equipment and vehicle to base specification.
6700 mm wheelbase available with 250 PS engine only.

Turning Circle (m)

WTW	Wall to Wall	16.9	17.7	18.8	19.9	20.9	22.1	23.4	24.6
KTK	Kerb to Kerb	15.4	16.3	17.3	18.4	19.4	20.6	21.9	23.1

Unladen Weights (kg +/- 2.5%)

Front axle	3715	3738	3751	3773	3785	3809	3827	3848
Rear axle	1861	1877	1892	1907	1932	1948	1953	1955
Total	5576	5615	5643	5680	5717	5757	5780	5803

Unladen weights are for vehicle in standard specification with full tanks of fuel and AdBlue® and include driver.

Plated/Operating Weights (kg)

		Design	UK Legal
GTW	Gross Train Weight ⁽¹⁾	33000	33000
GVW	Gross Vehicle Weight	18000	18000
	Front axle ⁽²⁾	7100	7100
	Rear axle	11500	11500

Tyre changes can affect legal weights. (1) Maximum value subject to specification. (2) 7500 kg upgrade optional.

Optional Equipment & Weights

Steel Rear Suspension	-2	NH/4c PTO	+6
Steel Front Bumper	+14	TN Cab	+235
Air Conditioning	+30	TM Cab	+250
9.00 x 22.5 Alloy Wheels	-82	DN Cab	+445
9 Speed Manual transmission	-16		

All weights indicated above subject to +/- 2.5% manufacturer's tolerance. Changes to standard equipment will alter kerb weights.

Engine Model - Euro 6	D0836LFLBK	D0836LFLBJ	D0836LFLBI	Features
Engine Power (PS)	250	290	320	<ul style="list-style-type: none"> ▪ Selective Catalytic Reduction ▪ Cruise Control ▪ Exhaust brake ▪ Road Speed Limiter (89 km/h) ▪ OBD-E ▪ Suitable for EN15940
Rated Speed (rpm)	2200	2200	2200	
Torque (Nm)	1050	1150	1250	
Torque Range (rpm)	1200 - 1600	1200 - 1700	1200 - 1700	
Cylinders	6	6	6	
Capacity (cc)	6871	6871	6871	

Performance at 18000 kg

Engine Power	Gearbox	Axle Ratio	Geared Road Speed (mph)	Engine RPM		Starting Grade	Tyre Size
				@55 mph	@50 mph		
250PS	12.12 OD	4.11:1	80	1507	1355	33%+	295/80R22.5
290PS	12.12 OD	4.11:1	80	1507	1355	33%+	295/80R22.5
320PS	12.12 OD	4.11:1	80	1507	1355	33%+	295/80R22.5

Clutch

Single plate 395mm diameter, asbestos free lining

Gearbox

12 Speed Tipmatic® Automated

Ratios

1	10.37
2	8.43
3	6.49
4	5.27
5	4.18
6	3.39
7	2.48
8	2.01
9	1.55
10	1.26
11	1.00
12	0.81
R1	10.56
R2	8.58

Frame

Construction	Bolted and riveted
Material	S500MC
Section	270 x 70 x 7 mm
Frame width	864 mm

Fuel Tank

Capacity	300 Litres
Section	Rectangular steel RHS mounted Locking cap

Axles

Steer	Drop beam
Drive	Single reduction

Suspension

Steer Axle	Single parabolic springs with shock absorbers and stabiliser
Drive Axle	Electronically controlled air suspension with shock absorbers and stabiliser

Rims & Tyres

Rims	Steer Steel 9.00 x 22.5 Drive Steel 8.25 x 22.5
Tyres	Steer 295/80R22.5 Drive 295/80R22.5

Electrical System

Type	CAN Bus system with central on-board computer
Voltage	24V
Alternator	110 AMP
Batteries	2 x 12v 175Ah

Steering

Type	Hydraulically assisted
------	------------------------

Braking System

Type	Electronic Brake System (EBS) with Anti-lock Braking System (ABS)
------	---

Features	Disc brakes, air dryer, asbestos free linings
----------	---

Parking Brake	Spring brakes on rear axle
---------------	----------------------------

Exhaust System

Ground discharge silencer, incorporating Diesel Particulate Filter (DPF)

General Equipment

35 Litre AdBlue® tank
Electronic immobiliser
Fuel filter with water separator
Pre-wired cargo space lighting
Mechanical battery master switch
Body mounting brackets
Audible reverse warning with night silent
Manual locking doors
Manual mirrors
Lane Guard System (LGS)
Emergency Brake Assist (EBA)
Electronic Stability Programme (ESP)
Adjustable roof spoiler
Lateral protection
Rear under run

TGM 18 TONNE 4X2 RIGID

Cab Options

'CC' Cab

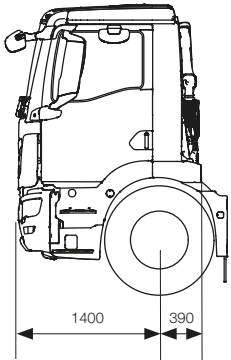

'TN' Cab

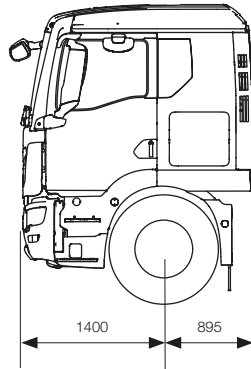

'TM' Cab

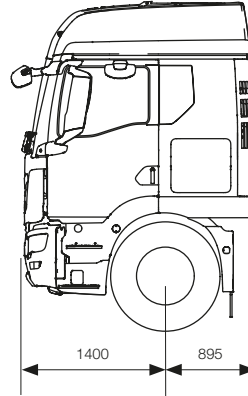

'DN' Cab

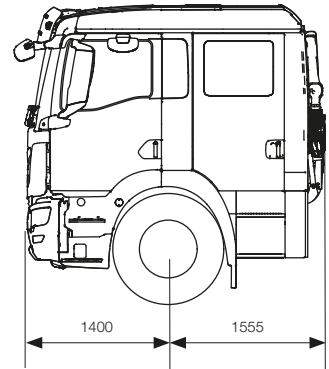

Sleeper Cab Body Lengths - TGM 18 Tonne 4x2 Rigid

TN Sleeper

L1	Wheelbase		4425	4725	5075	5425	5775	6175	6575	6575
L17	Min. recommended body length	mm	4653	5108	5633	6164	6687	7297	7907	8522
		ft.ins.	15'3"	16'9"	18'6"	20'3"	21'11"	23'11"	25'11"	27'11"
	Max. recommended body length	mm	5089	5575	6135	6703	7263	7914	8295	8695
		ft.ins.	16'8"	18'3"	20'2"	22'0"	23'10"	26'0"	27'3"	28'6"

Recommended body length only applicable to bodies with UDL, without auxiliary equipment and vehicle to base specification.

Sleeper Cab Body Lengths - TGM 18 Tonne 4x2 Rigid

TM Sleeper

L1	Wheelbase		4425	4725	5075	5425	5775	6175	6575	6575
L17	Min. recommended body length	mm	4661	5117	5642	6174	6698	7308	7919	8535
		ft.ins.	15'4"	16'9"	18'6"	20'3"	22'0"	24'0"	26'0"	28'0"
	Max. recommended body length	mm	5097	5584	6145	6713	7274	7926	8295	8695
		ft.ins.	16'9"	18'4"	20'2"	22'0"	23'10"	26'0"	27'3"	28'6"

Recommended body length only applicable to bodies with UDL, without auxiliary equipment and vehicle to base specification.

MAN Truck & Bus UK Ltd.,
 Frankland Road, Blagrove,
 Swindon. Wiltshire SN5 8YU
www.mantruckandbus.co.uk

Ref: MAN TGM 18T4X2RIG / 12
 Issue Date: May 2022
 Technical illustrations are not binding.
 Front cover picture may not be standard equipment.
 We reserve the right to make modifications in line with technical progress.