

TGL 7.5 TONNE 4X2 TIPPER

Chassis Specification:

TGL 8.160 4x2 BB CH

TGL 8.190 4x2 BB CH



TGL 7.5 TONNE 4X2 TIPPER

TGL 8.160 4x2 BB CH

TGL 8.190 4x2 BB CH

Base Cab Model TGL 'CC' Cab

For cab variants, options and specifications see separate cab specification sheet.

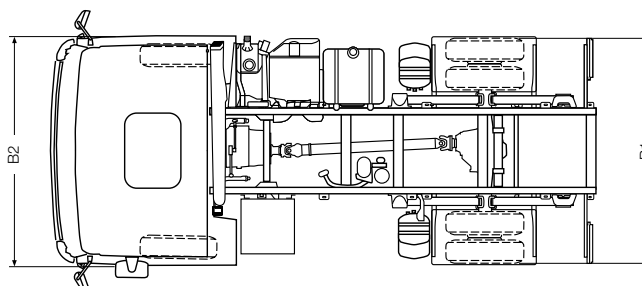
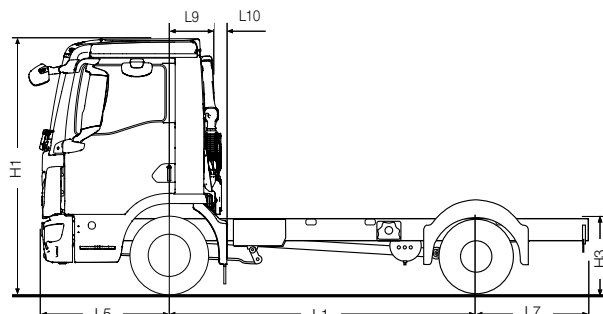

Vehicle Dimensions (mm)

Dimension	Description	3050	3600
L1	Wheelbase	3050	3600
L5	Front overhang	1275	1275
L7	Rear overhang	1075	1275
L9	Centre line front axle to back of cab	515	515
L10	Back of cab to start of body/equipment	50	50
B1	Width across rear tyres	2188	2188
B2	Cab width over wings	2300	2300
H1	Cab height		
	- laden	2565	2565
	- unladen	2602	2602
H3	Frame height at centre rear wheels		
	- laden	748	748
	- unladen	836	836

Turning Circle (m)

Measurement	Description	12.6	14.1
WTW	Wall to Wall	12.6	14.1
KTK	Kerb to Kerb	11.0	12.5

Unladen Weights (kg +/- 2.5%)

Front axle	2713	2724
Rear axle	937	973
Total	3650	3697

Unladen weights are for vehicle in standard specification with full tanks of fuel and AdBlue® and include driver.

Plated/Operating Weights (kg)

Weight Type	Description	Design	UK Legal
GTW	Gross Train Weight ⁽¹⁾	18750	18750
GVW	Gross Vehicle Weight	7500	7500
Front axle ⁽²⁾		3400	3400
Rear axle		5200	5200

Tyre changes can affect legal weights. (1) Maximum value subject to specification. (2) 3800 kg upgrade optional.

Optional Equipment & Weights

150 Ah Batteries	+32	3800 kg plated front axle (inc tyres)	16
Air Conditioning	+30	TipMatic® transmission	+16
6.75 x 17.5 Alloy Wheels	-48		

All weights indicated above subject to +/- 2.5% manufacturer's tolerance. Changes to standard equipment will alter kerb weights.

Engine Model - Euro 6	D0834LFLAS	D0834LFLAR	Features
Engine Power (PS)	160	190	<ul style="list-style-type: none"> Selective Catalytic Reduction
Rated Speed (rpm)	2300	2300	<ul style="list-style-type: none"> Cruise Control
Torque (Nm)	600	750	<ul style="list-style-type: none"> Exhaust brake
Torque Range (rpm)	1000 - 1850	1200 - 1750	<ul style="list-style-type: none"> Road Speed Limiter (89 km/h)
Cylinders	4	4	<ul style="list-style-type: none"> OBD-E
Capacity (cc)	4850	4850	<ul style="list-style-type: none"> Suitable for EN15940

Performance at 7500 kg

Engine Power	Gearbox	Axle Ratio	Geared Road Speed (mph)	Engine RPM		Starting Grade	Tyre Size
				@55 mph	@50 mph		
160PS	06.08 OD	4.11:1	63	2014	1810	33%+	215/75/R17.5
190PS	06.08 OD	4.11:1	63	2014	1810	33%+	215/75/R17.5

Clutch

Single plate 395mm diameter, asbestos free lining

Gearbox

6 Speed Manual

Ratios

1	6.58
2	3.60
3	2.13
4	1.39
5	1.00
6	0.78
R	6.06

Frame

Construction	Bolted and riveted
Material	S420MC
Section	270 x 70 x 4.5 mm
Frame width	859 mm

Fuel Tank

Capacity	100 Litres
Section	Rectangular steel RHS mounted Locking cap

Axles

Steer	Drop beam
Drive	Single reduction with differential lock

Suspension

Steer Axle	Single parabolic springs with shock absorbers and stabiliser
Drive Axle	Single parabolic springs with shock absorbers and stabiliser

Rims & Tyres

Rims	Steel 6.00 x 17.5
Tyres	Steer 215/75R17.5 Drive 215/75R17.5

Electrical System

Type	CAN Bus system with central on-board computer
Voltage	24V
Alternator	110 AMP
Batteries	2 x 12v 88Ah

Steering

Type	Hydraulically assisted
------	------------------------

Braking System

Type	Electronic Brake System (EBS) with Anti-lock Braking System (ABS)
------	---

Features Disc brakes, air dryer, asbestos free linings

Parking Brake Spring brakes on rear axle

Exhaust System

Ground discharge silencer, incorporating Diesle Particulate Filter (DPF)

General Equipment

35 Litre AdBlue® tank
Electronic immobiliser
Fuel filter with water separator
Mechanical battery master switch
Audible reverse warning with night silent
Manual locking doors
Manual mirrors
Lane Guard System (LGS)
Emergency Brake Assist (EBA)
Electronic Stability Programme (ESP)
NH/4c Power Take Off (PTO)
Lateral protection
Preparation wiring for roof beacons
Rear cab window
Rear under run

TGL 7.5 TONNE 4X2 TIPPER

Cab Options

'CC' Cab

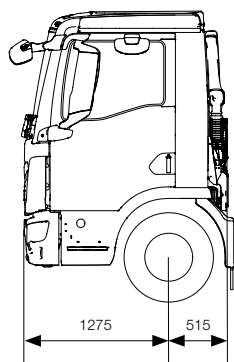

MAN Truck & Bus UK Ltd.,
Frankland Road, Blagrove,
Swindon. Wiltshire SN5 8YU
www.mantruckandbus.co.uk

Ref: MAN TGL 8T4X2TIP / 11

Issue Date: May 2022

Technical illustrations are not binding.

Front cover picture may not be standard equipment.

We reserve the right to make modifications in line with technical progress.