

TGL 7.5 TONNE 4X2 RIGID

Chassis Specification:

TGL 8.160 4x2 BL CH

TGL 8.190 4x2 BL CH

TGL 8.220 4x2 BL CH



TGL 7.5 TONNE 4X2 RIGID

TGL 8.160 4x2 BL CH

TGL 8.190 4x2 BL CH

TGL 8.220 4x2 BL CH

Base Cab Model TGL 'CC' Cab

For cab variants, options and specifications see separate cab specification sheet.

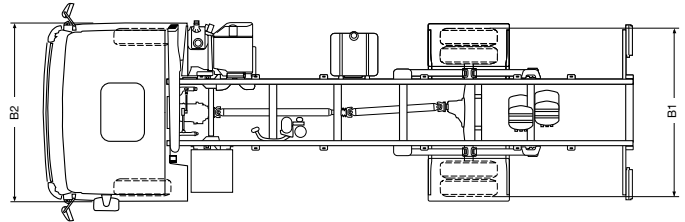
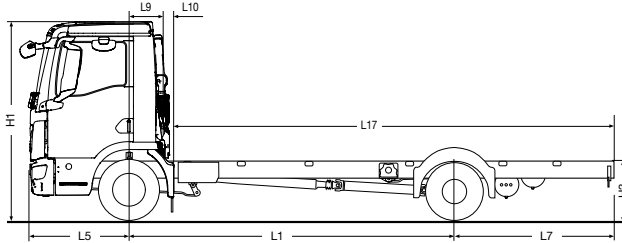

Vehicle Dimensions (mm)

| | | 3600 | 3900 | 4200 | 4500 | 4850 | 5200 | 5550 | |
|-----|--|-----------|-------|--------|--------|-------|--------|--------|-------|
| L1 | Wheelbase | 3600 | 3900 | 4200 | 4500 | 4850 | 5200 | 5550 | |
| L5 | Front overhang | 1275 | 1275 | 1275 | 1275 | 1275 | 1275 | 1275 | |
| L7 | Rear overhang | 1925 | 2125 | 2125 | 2475 | 2675 | 2875 | 3075 | |
| L9 | Centre line front axle to back of cab | 515 | 515 | 515 | 515 | 515 | 515 | 515 | |
| L10 | Back of cab to start of body/equipment | 50 | 50 | 50 | 50 | 50 | 50 | 50 | |
| L17 | Min. recommended body length | 4868 | 5322 | 5802 | 6281 | 6799 | 7301 | 7827 | |
| | | mm | | | | | | | |
| | | ft.ins. | 16'0" | 17'6" | 19'0" | 20'7" | 22'4" | 23'11" | 25'8" |
| | Max. recommended body length | 4960 | 5460 | 5760 | 6410 | 6960 | 7510 | 8060 | |
| | | mm | | | | | | | |
| | | ft.ins. | 16'3" | 17'11" | 18'11" | 21'0" | 22'10" | 24'8" | 26'5" |
| B1 | Width across rear tyres | 2188 | 2188 | 2188 | 2188 | 2188 | 2188 | 2188 | |
| B2 | Cab width over wings | 2300 | 2300 | 2300 | 2300 | 2300 | 2300 | 2300 | |
| H1 | Cab height | 2565 | 2565 | 2565 | 2565 | 2565 | 2565 | 2565 | |
| | | - laden | | | | | | | |
| | | - unladen | 2602 | 2602 | 2602 | 2602 | 2602 | 2602 | |
| H3 | Frame height at centre rear wheels | 764 | 764 | 764 | 764 | 764 | 764 | 764 | |
| | | - laden | | | | | | | |
| | | - unladen | 784 | 784 | 784 | 784 | 784 | 784 | |

Recommended body length only applicable to bodies with UDL, without auxiliary equipment and vehicle to base specification.

Turning Circle (m)

| | | | | | | | | |
|-----|--------------|------|------|------|------|------|------|------|
| WTW | Wall to Wall | 14.1 | 15.0 | 15.9 | 16.8 | 17.8 | 18.8 | 19.8 |
| KTK | Kerb to Kerb | 12.2 | 13.4 | 14.2 | 15.1 | 16.1 | 17.2 | 18.2 |

Unladen Weights (kg +/- 2.5%)

| | | | | | | | |
|------------|------|------|------|------|------|------|------|
| Front axle | 2794 | 2776 | 2770 | 2767 | 2749 | 2729 | 2721 |
| Rear axle | 1077 | 1113 | 1124 | 1148 | 1186 | 1227 | 1262 |
| Total | 3871 | 3889 | 3894 | 3915 | 3935 | 3956 | 3983 |

Unladen weights are for vehicle in standard specification with full tanks of fuel and AdBlue® and include driver.

Plated/Operating Weights (kg)

| | | Design | UK Legal |
|---------------------------|-----------------------------------|--------|----------|
| GTW | Gross Train Weight ⁽¹⁾ | 18750 | 18750 |
| GVW | Gross Vehicle Weight | 7500 | 7500 |
| Front axle ⁽²⁾ | | 3400 | 3400 |
| Rear axle | | 5200 | 5200 |

Tyre changes can affect legal weights. (1) Maximum value subject to specification. (2) 3800 kg upgrade optional.

Optional Equipment & Weights

| | | | |
|---------------------------------------|-----|---------------------|------|
| Steel Rear Suspension | -88 | Manual transmission | -16 |
| 150 Ah Batteries | +32 | NH/4c PTO | +6 |
| Air Conditioning | +30 | TN Cab | +270 |
| 6.75 x 17.5 Alloy Wheels | -48 | TM Cab | +285 |
| 3800 kg plated front axle (inc tyres) | +16 | DN Cab | +520 |

All weights indicated above subject to +/- 2.5% manufacturer's tolerance. Changes to standard equipment will alter kerb weights.

| Engine Model - Euro 6 | D0834LFLAS | D0834LFLAR | D0834LFLAQ | Features |
|-----------------------|-------------|-------------|-------------|---|
| Engine Power (PS) | 160 | 190 | 220 | <ul style="list-style-type: none"> ▪ Selective Catalytic Reduction ▪ Cruise Control ▪ Exhaust brake ▪ Road Speed Limiter (89 km/h) ▪ OBD-E ▪ Suitable for EN15940 |
| Rated Speed (rpm) | 2300 | 2300 | 2300 | |
| Torque (Nm) | 600 | 750 | 850 | |
| Torque Range (rpm) | 1000 - 1850 | 1200 - 1750 | 1300 - 1800 | |
| Cylinders | 4 | 4 | 4 | |
| Capacity (cc) | 4850 | 4850 | 4850 | |

Performance at 7500 kg

| Engine Power | Gearbox | Axle Ratio | Geared Road Speed (mph) | Engine RPM | | Starting Grade | Tyre Size |
|--------------|----------|------------|-------------------------|------------|---------|----------------|--------------|
| | | | | @55 mph | @50 mph | | |
| 160PS | 06.08 OD | 3.36:1 | 77 | 1647 | 1480 | 33%+ | 215/75/R17.5 |
| 190PS | 06.08 OD | 3.36:1 | 77 | 1647 | 1480 | 33%+ | 215/75/R17.5 |
| 220PS | 06.08 OD | 3.36:1 | 77 | 1647 | 1480 | 33%+ | 215/75/R17.5 |

Clutch

Single plate 395mm diameter, asbestos free lining

Gearbox

6 Speed Tipmatic® Automated

Ratios

| | |
|---|------|
| 1 | 6.58 |
| 2 | 3.60 |
| 3 | 2.13 |
| 4 | 1.39 |
| 5 | 1.00 |
| 6 | 0.78 |
| R | 6.06 |

Frame

| | |
|--------------|--------------------|
| Construction | Bolted and riveted |
| Material | S420MC |
| Section | 270 x 70 x 4.5 mm |
| Frame width | 859 mm |

Fuel Tank

| | |
|----------|---|
| Capacity | 150 Litres |
| Section | Rectangular steel RHS mounted Locking cap |

Axles

| | |
|-------|------------------|
| Steer | Drop beam |
| Drive | Single reduction |

Suspension

| | |
|------------|--|
| Steer Axle | Single parabolic springs with shock absorbers and stabiliser |
| Drive Axle | Electronically controlled air suspension with shock absorbers and stabiliser |

Rims & Tyres

| | |
|-------|--|
| Rims | Steel 6.00 x 17.5 |
| Tyres | Steer 215/75R17.5 Drive 215/75R17.5 |

Electrical System

| | |
|------------|---|
| Type | CAN Bus system with central on-board computer |
| Voltage | 24V |
| Alternator | 110 AMP |
| Batteries | 2 x 12v 88Ah |

Steering

| | |
|------|------------------------|
| Type | Hydraulically assisted |
|------|------------------------|

Braking System

| | |
|------|---|
| Type | Electronic Brake System (EBS) with Anti-lock Braking System (ABS) |
|------|---|

Features Disc brakes, air dryer, asbestos free linings

Parking Brake Spring brakes on rear axle

Exhaust System

Ground discharge silencer, incorporating Diesle Particulate Filter (DPF)

General Equipment

| |
|---|
| 35 Litre AdBlue® tank |
| Electronic immobiliser |
| Fuel filter with water separator |
| Pre-wired cargo space lighting |
| Mechanical battery master switch |
| Body mounting brackets |
| Audible reverse warning with night silent |
| Manual locking doors |
| Manual mirrors |
| Lane Guard System (LGS) |
| Emergency Brake Assist (EBA) |
| Electronic Stability Programme (ESP) |
| Adjustable roof spoiler |
| Lateral protection |
| Rear under run |

TGL 7.5 TONNE 4X2 RIGID

Cab Options

'CC' Cab

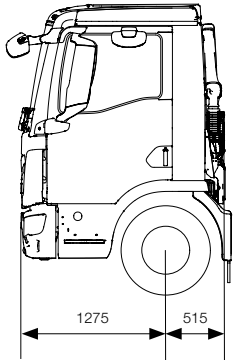

'TN' Cab

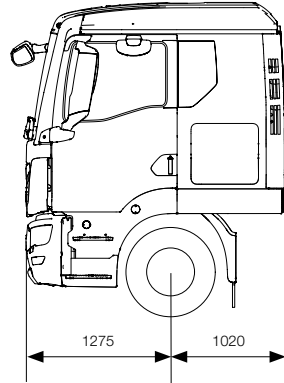

'TM' Cab

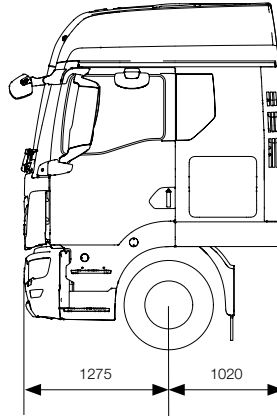

'DN' Cab

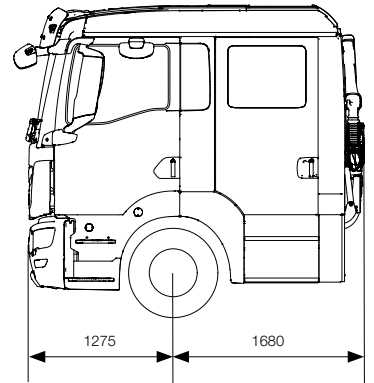

Sleeper Cab Body Lengths - TGL 7.5 Tonne 4x2 Rigid

TN Sleeper

| L1 | Wheelbase | | 3600 | 3900 | 4200 | 4500 | 4850 | 5200 | 5550 |
|-----|------------------------------|---------|-------|--------|-------|-------|-------|--------|-------|
| L17 | Min. recommended body length | mm | 4320 | 4814 | 5334 | 5854 | 6418 | 6966 | 7542 |
| | | ft.ins. | 14'2" | 15'10" | 17'6" | 19'2" | 21'1" | 22'10" | 24'9" |
| | Max. recommended body length | mm | 4445 | 4945 | 5245 | 5895 | 6445 | 6995 | 7545 |
| | | ft.ins. | 14'7" | 16'3" | 17'2" | 19'4" | 22'1" | 22'11" | 24'9" |

Recommended body length only applicable to bodies with UDL, without auxiliary equipment and vehicle to base specification.

Sleeper Cab Body Lengths - TGL 7.5 Tonne 4x2 Rigid

TM Sleeper

| L1 | Wheelbase | | 3600 | 3900 | 4200 | 4500 | 4850 | 5200 | 5550 |
|-----|------------------------------|---------|-------|--------|-------|-------|-------|--------|--------|
| L17 | Min. recommended body length | mm | 4349 | 4845 | 5367 | 5891 | 6458 | 7008 | 7587 |
| | | ft.ins. | 14'3" | 15'11" | 17'7" | 19'4" | 21'2" | 23'0" | 24'11" |
| | Max. recommended body length | mm | 4445 | 4945 | 5245 | 5895 | 6445 | 6995 | 7545 |
| | | ft.ins. | 14'7" | 16'3" | 17'2" | 19'4" | 22'1" | 22'11" | 24'9" |

Recommended body length only applicable to bodies with UDL, without auxiliary equipment and vehicle to base specification.

MAN Truck & Bus UK Ltd.,
 Frankland Road, Blagrove,
 Swindon. Wiltshire SN5 8YU
www.mantruckandbus.co.uk

Ref: MAN TGL 8T4X2RIG / 12

Issue Date: May 2022

Technical illustrations are not binding.

Front cover picture may not be standard equipment.

We reserve the right to make modifications in line with technical progress.