

# MAN TGL & TGM

## Cab Specifications



# TGL & TGM CAB SPECIFICATIONS

## Cab Type - 'CC' Compact Day

- Comfort driver seat with air suspension
- Co-driver seat with storage box
- Mechanically sprung cab suspension system
- Folding sun visors
- Manual door locks
- Electric windows and Manually adjusting mirrors
- Storage net on cab rear wall

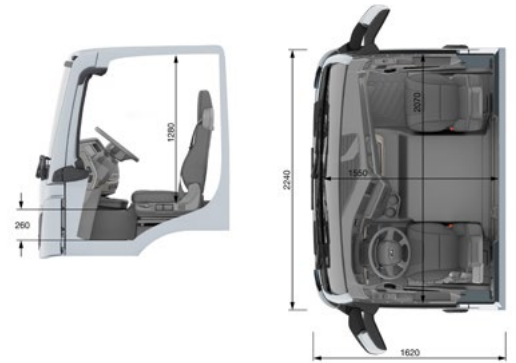

## Cab Type - 'TN' Normal Height Sleeper

- Comfort driver seat with air suspension
- Co-driver seat with storage box
- Generous single bunk with 90mm foam mattress
- Two exterior storage lockers - both accessible from inside
- Mechanically sprung cab suspension system
- Folding sun visors
- Drivers roller sun blind
- Central locking
- Under bunk storage
- Electric windows and Electric adjusting mirrors (not front view mirror)

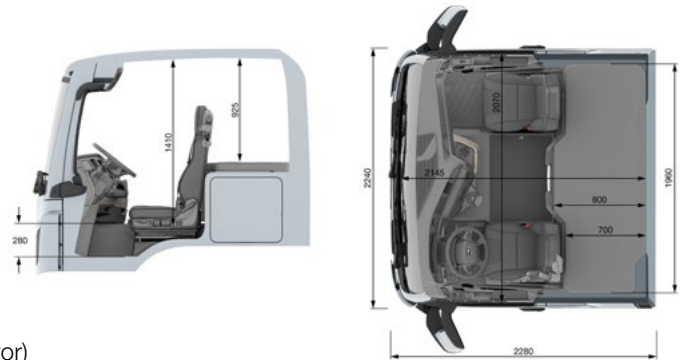

## Cab Type - 'TM' Medium Height Sleeper

- Comfort driver seat with air suspension
- Co-driver seat with storage box
- Generous single bunk with 90mm foam mattress
- Two exterior storage lockers - both accessible from inside
- Mechanically sprung cab suspension system
- Folding sun visors
- Drivers roller sun blind
- Central locking
- Under bunk storage
- Over head storage with 3 compartments
- Electric windows and Electric adjusting mirrors (not front view mirror)

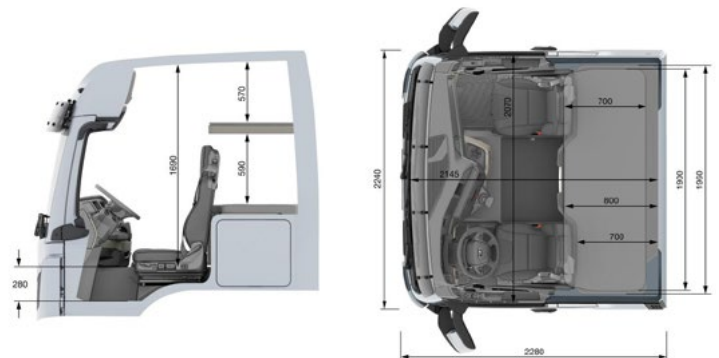

## Cab Type - 'DN' Crew Cab

- Driver Seat with air suspension
- Co-driver seat with storage box
- Middle seat with 3-point seatbelt
- Rear bench seat for 4 persons
- 4 doors
- Comfort air suspension cab mounting
- Folding sun visors
- Central locking
- Electric windows and Electric adjusting mirrors (not front view mirror)
- Manual roof hatch

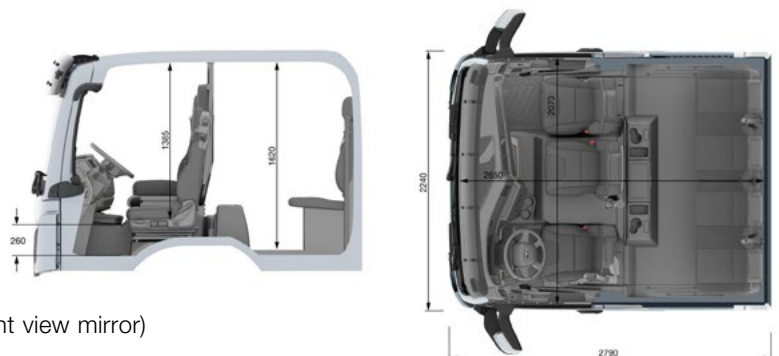

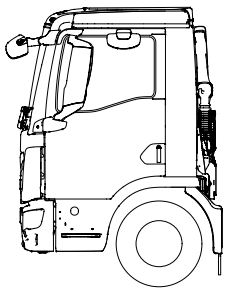

CC Cab

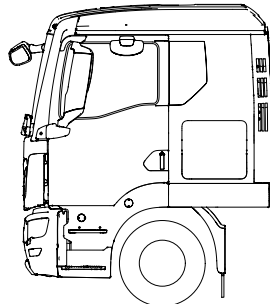

TN Cab

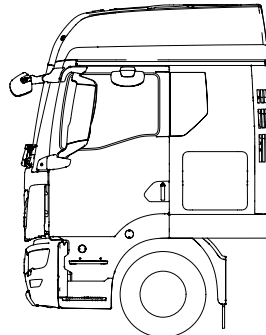

TM Cab

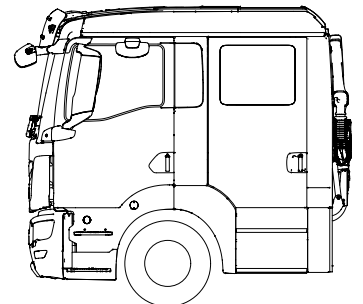

DN Cab

## STANDARD EQUIPMENT

### Exterior

- Cab colour - Pure white RAL 9016:
- (Lower cab parts in standard factory grey including bumper, wings and step area)
- Rear view and wide angle mirrors
- Kerb and front view mirrors
- Mechanical cab suspension
- Hydraulic tilt to 62 degrees
- Under bumper air dam
- Vehicle toolkit

### Interior

- Moon Grey cab interior
- DSRC Digital tachograph with remote download
- MAN media system, 7"
- Bluetooth connectivity
- Internal folding sunvisor
- Rubber floor covering
- Soft trim roof liner
- Soft trim interior
- Washable door panels
- Driving hours indicator in the instrumentation
- Electric windows
- Central interior light
- Reading lights in bunk area (where applicable)

### Safety

- Seat belts for all seats
- Seatbelt warning for first row of seats
- Head restraints for all seats
- Entry lighting
- Non slip entry steps
- Cruise control
- Multifunction steering wheel

### Storage

- Header rail storage
- Storage pockets in both doors
- Storage pockets on rear cab wall
- Under bunk storage (sleeper cab only)
- 2 external lockers - both accessible from inside

### Heating & Ventilation

- Heating system with variable fan speed control

### Seats

- Adjustable High back driver seat with cloth trim
- Adjustable High back co-driver seat with cloth trim

### Windows

- Laminated tinted windscreen

## OPTIONAL EQUIPMENT

### Exterior

	CC	TN	TM	DN
Electrically adjustable & heated rear view mirrors	o	s	s	s
MAN Optiview mirrorless system	o	o	o	o
Remote central locking	o	o	o	o
Twin air horns on cab roof	o	o	o	o
External sun visor	o	o	o	o
Steel front bumper (Not TGL with CC cab)	o	o	o	o
Adjustable roof spoiler	o	o	o	o

### Interior

MAN Media system, 7"	s	s	s	s
MAN Advanced media system, 7"	o	o	o	o
MAN Advanced media system, navigation, 7"	o	o	o	o
Professional instrumentation, 12.3"	o	o	o	o
MAN Smart Select infotainment control	-	o	o	-
MAN Advanced sound system with subwoofer	-	o	o	-
Pull out tray table on co-driver's side	o	o	o	o
Auxiliary 12v/24v sockets	o	s	s	s
Manual roof hatch	o	s	s	s
Glass sunroof	-	o	o	-
110 mm comfort bed mattress	-	o	o	-
Second bunk	-	-	o	-

### Safety

Combined fog and spot lamps	o	o	o	o
Driver's airbag	o	o	o	o
Electronic park brake (dashboard mounted)	o	o	o	o
LED headlamps	o	o	o	o
Headlamp washer system	o	o	o	o
Fire extinguisher	o	o	o	o

### Storage

	CC	TN	TM	DN
Centre storage box	o	s	s	o
Pull out fridge	-	o	o	-

### Heating & Ventilation

Night heater	o	s	s	o
Air conditioning with automatic temp control	o	o	o	o
Climate control	o	o	o	o

### Seats

Air suspended driver seat	s	s	s	s
Air suspended driver seat with lumbar support and shoulder adjustment	o	o	o	o
Comfort seat covers	o	s	s	o
Part leather seat covers	-	o	o	-
Air suspended co-driver seat	o	o	o	o
Air suspended co-driver seat with lumbar support and shoulder adjustment	o	o	o	o
Folding co-driver's seat	o	o	o	o
Folding and turning co-driver's seat	-	o	o	-
2nd co-driver's seat (middle)	o	-	-	s

### Windows

Windows in rear of cab wall	o*	o	o	o
Electric roller blind for windscreen	-	o	o	-
Roller blind for driver's Door	o	s	s	o
Roller blind for passenger Door	o	o	o	o
Heated laminated tinted windscreen	o	o	o	o

S = Standard O = Optional \*Standard on construction models

### MAN Truck & Bus UK Ltd.,

Frankland Road, Blagrove,  
Swindon. Wiltshire SN5 8YU  
www.mantruckandbus.co.uk

Ref: MAN TGL & TGM Cab Spec / 11

Issue Date: May 2022

Technical illustrations are not binding.

Front cover picture may not be standard equipment.

We reserve the right to make modifications in line with technical progress.