



Bodybuilder's Bulletin

21 May 2010

Bulletin No. 112

Subframe Requirements for Tipper Installation

We are issuing this bulletin as a reminder with respect to subframe requirements for tipper installations on MAN product.

All vehicles require a subframe for tipper bodies **except** the following chassis types:

TGM	6x4 Tipper	(Chassis type LN48)
TGS	8x4 Rigid/Tipper	(Chassis type L49S)
TGS	8x4 Heavy Duty Tipper	(Chassis type L37S)

In addition to the three chassis types listed above, the TGS 6x4 Rigid (chassis type L26S) can be fitted with a tipper body without a subframe providing the following modifications to the chassis are made:

- Installation of 8x4 type rear cross member (Part No 81.41250.5187)
- Installation of chassis flitching (see drawing on following page)

NB. Grab crane/tippers require a full length subframe irrespective of what chassis type is used.

Should you have any queries on the above, please contact Product Engineering on 01793 448170 or email bodybuilder@man.co.uk.

Please circulate and then retain in the Bodybuilder's Manual

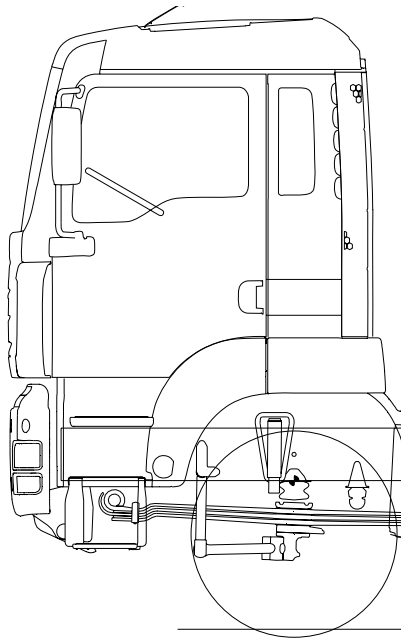

FLITCH DETAIL
MAT'L: QStE420TM

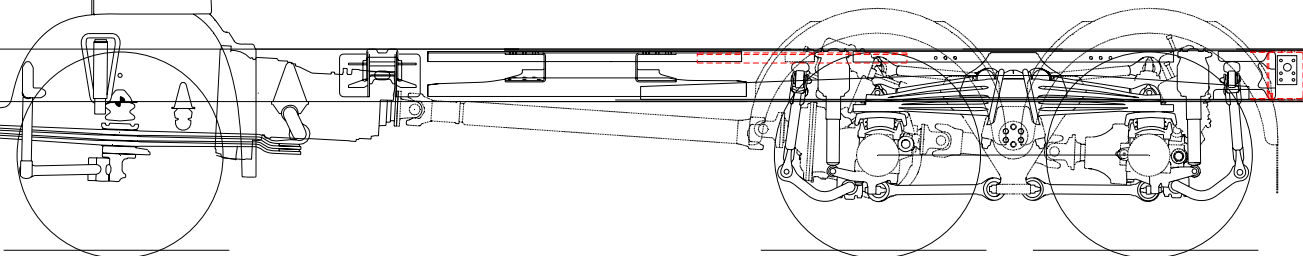
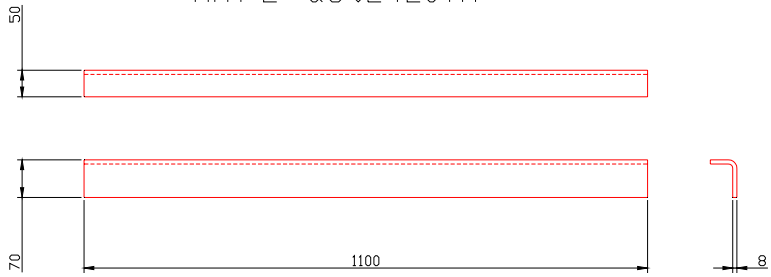

REPLACE EXISITING CROSS MEMBER WITH 81.41250.5187

2 No. FOLDED FLITCHES BOLTED INSIDE
CHASSIS RAILS AS SHOWN (PACKERS REQUIRED)

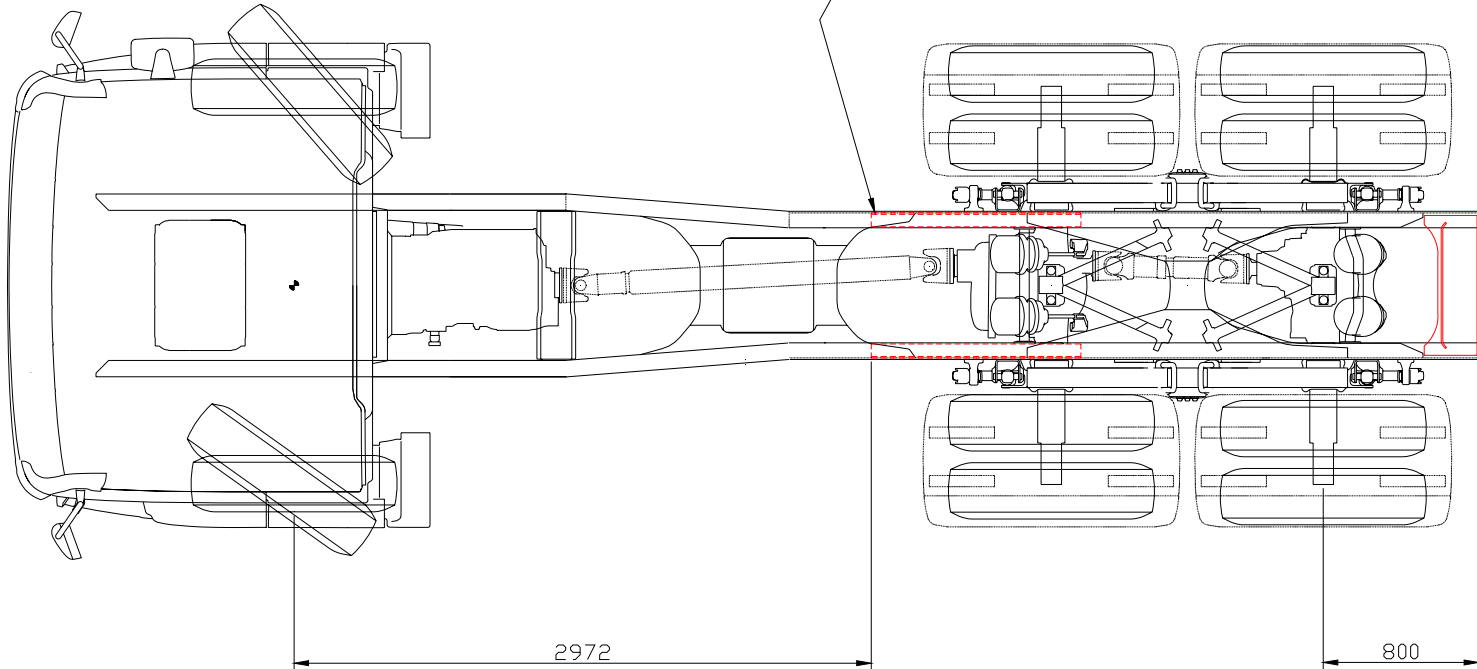

L26S 6x4 3900mm wheelbase