

Bodybuilder's Bulletin

08 July 2009

Bulletin No. 108

Body Runners on TGL/TGM Sleeper cabs

The installation of the air cleaner on all TGL & TGM sleeper cab chassis is different to that of the day cab, in that the element housing is centrally mounted under the rear of the cab with the inlet mounted vertically on the nearside rear of the cab.

Because of this, the intake trunking passes over the nearside chassis rail, but is designed to allow the body longitudinal to pass underneath.

However, the available space is approximately 125mm which therefore allows for bodyrunners of no more than 120mm in the location of the trunking to ensure adequate clearance remains.

When using bodyrunners in excess of 120mm, these will have to be profiled to fit under this trunking to gain access to the foremost body mounting bracket.

Please note that all bodyrunners **must** extend past the rearmost front spring hanger bracket as shown in the 'Guidelines to Fitting Bodies – Section 5.3.3' –see below

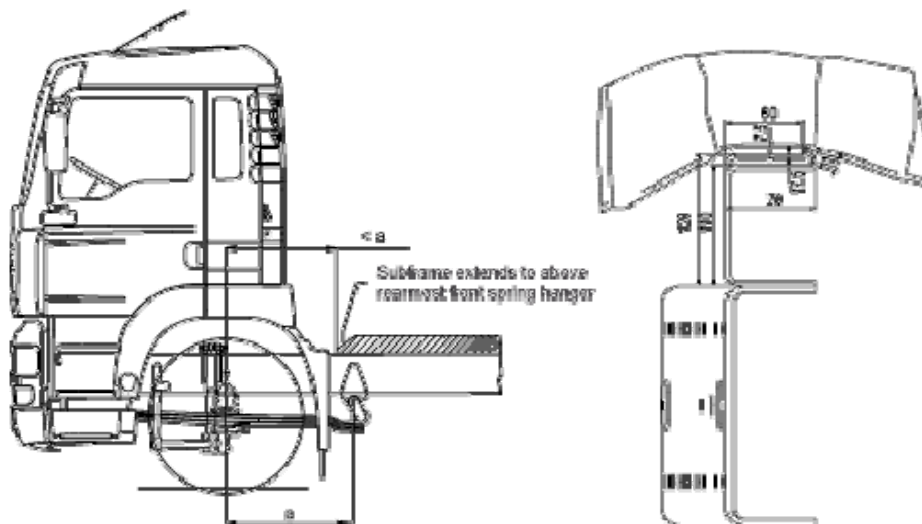

Should you have any queries on the above, please contact Product Engineering on 01793 448170 or email bodybuilder@man.co.uk.

Please circulate and then retain in the Bodybuilder's Manual