

## Bodybuilder's Bulletin

26 March 2008

Bulletin No. 101

### TGM 6x4 Tipper overhang

The TGM 6x4 tipper has been designed for 'normal' front end tipper operation without the need to have an additional subframe.

A special rear cross member has been designed and installed during production to enable this capability.

However, the frame side members protrude beyond the final crossmember and these must be cut off flush (or near flush) with the rear face of the final member.

It is **not allowed** to install a hinge-pin in the area of chassis frame beyond the final crossmember.

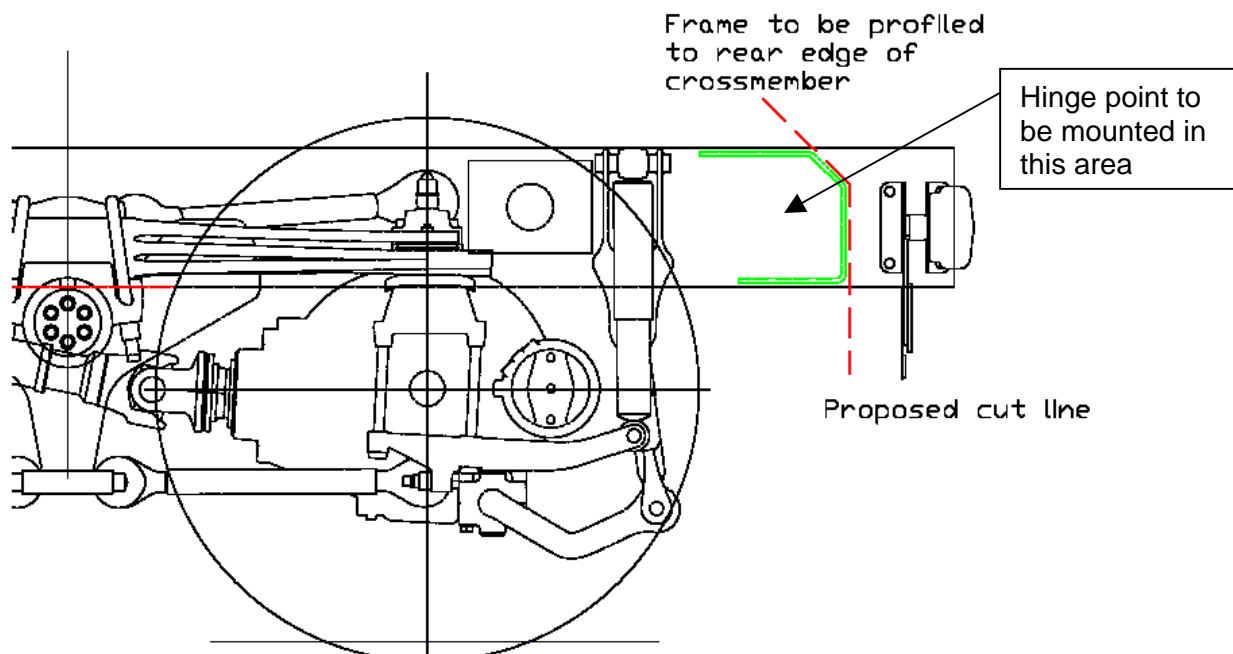

*Should you have any queries on the above, please contact Product Engineering on 01793 448170 or email [bodybuilder@man.co.uk](mailto:bodybuilder@man.co.uk).*

**Please circulate and then retain in the Bodybuilder's Manual**